

Ups and Downs in the Theory of Temporal Reference

Uwe Reyle, Antje Rossdeutscher, Hans Kamp

Part I. Tenses, Locating and Quantificational Adverbs, Aspect Operators

1 Purpose and Framework

This paper proposes an algorithm which computes the temporal aspects of the interpretations of a variety of German sentences. The algorithm is strictly modular in the sense that it allows each meaning-bearing sentence constituent to make its own, separate, contribution to the semantic representation of any sentence containing it. The algorithm is to be seen as part of a larger one which computes all aspects of semantic representation, non-temporal as well as temporal ones.

The semantic representation of a sentence is reached in several stages. First, an ‘initial semantic representation’ is constructed, using a syntactic analysis of the sentence as input. This initial representation is then transformed into the definitive representation by a series of transformations which reflect the ways in which the contributions from different constituents of the sentence interact. In this paper it is the temporal interactions on which we focus.

Since the different constituents which make their respective contributions to the meaning of the sentence are in most instances ambiguous, the initial representations typically involve a high degree of underspecification. Usually the ambiguities can be resolved in the context provided by the sentence as a whole. But to resolve them we have to start from a sentence representation which identifies this context. This represen-

tation must have the form of a semantic representation, but it must be one in which the ambiguities are yet to be resolved, thus it will be an ‘underspecified’ representation.

The framework we will be using is that of UDRT (Underspecified Discourse Representation Theory). The general implications of this are, we take it, known well enough: To construct the semantic representation of a sentence one first establishes, on the basis of an underlying syntactic representation of the sentence in question, an Underspecified Discourse Representation Structure (UDRS), and this representation is then transformed into a succession of less ambiguous representations. In the ideal case the final result of these transformations is a semantic representation of the sentence which is free of ambiguity (a Discourse Representation Structure, or DRS), but there are also cases where certain ambiguities cannot be eliminated, so that the end product of the transformations is still a UDRS (though usually one of a lower degree of ambiguity than the initial UDRS). Sometimes the remaining ambiguities are eliminable in the wider context of the discourse to which the sentence belongs or the external conditions under which the sentence is used. Important for what we will propose is also that UDRSs have the form of partially ordered sets of DRS-like component representations.

The choice of UDRT as a general framework does not entail much by way of commitments to the details of how exactly the interpretation of temporal expressions should be handled. A decade of experience with underspecification has made us increasingly alert to the fact that ambiguity comes in many different forms and that for each new type of ambiguity both its representation and the mechanisms for resolving it present a challenge that has to be met in its own way. We have found this to be true also for the temporal aspects of meaning which are the theme of this paper: The problems connected with the representation and resolution of time-related ambiguities differ significantly from others, and in particular from those for which UDRS-based proposals have been around for some time (certain scope ambiguities, certain lexical ambiguities, collective-distributive ambiguities and more. See [48], [58], [49], [29] [25].)

The representation-disambiguation algorithm that is proposed in this paper thus looks quite different from earlier proposals we have made for the ambiguity types just mentioned. The mode of underspecified repre-

sentation that we will present, and the form of the resolution mechanisms connected with it, are shaped to a large extent by the assumption that different elements of temporal interpretation get introduced in different places in the initial representation, but must nevertheless be connected with each other in order that the intended temporal relations can be established. The most salient instance of this problem concerns the connection of the information contributed by the tenses and that which is associated with the lexical verbs which bear them. We assume that a lexical verb introduces a representation of the eventuality (state or event) it is being used to describe while its tense introduces information which serves to locate the eventuality within some temporal frame, and that the bits of information that verb and tense introduce end up in different places of the initial representation. This separation can be seen as a reflection, at the level of initial semantic representation, of the familiar assumption in generative syntax that tense information is located at a node fairly high up in the syntactic tree (referred to in the literature variously as ‘AUX’, ‘Infl’, ‘I’ or ‘T’), whereas the verb itself is found at some different node lower down. And just as it is assumed by many involved in current syntactic theory that the lexical contribution made by the verb and the information contributed by tense have to be brought into contact by movement (of the verb to the higher ‘tense’ node) in the course of constructing LF, so it is a central function of the temporal resolution mechanism we will present here to link the eventuality introduced by the lexical verb with the conditions introduced by its tense.

In the algorithm we present in this paper the temporal links that the resolution mechanism must establish are always between a ‘lower’ and a ‘higher’ UDRS-component (in the sense of the partial ordering of the UDRS). This has led us to adopt a form of initial representation of temporal information which makes use of two types of temporal variables, those which carry a requirement of linking with a temporal variable farther down (indicated by the downward arrow \downarrow) and those which must be linked with a variable higher up (indicated by the upward arrow \uparrow). The resulting notation is reminiscent of that used in Lexical Functional Grammar to compute F-structures from C-structures, though admittedly the analogy is not a deep one.

2 Ambiguity, Compositionality and Under-specification

When in the sixties Montague showed that many aspects of meaning in natural language are governed by general principles of compositionality, which determine how the meanings of syntactically complex expressions depend on the meanings of their constituents, this was a true revelation to many. Since then we have come to see compositionality as a property which natural languages possess as a matter of course, and which in fact they could not fail to possess given how people learn and use them. And much of the work within natural language semantics that has been done from that time onwards has followed Montague in trying to uncover the principles which govern the systematic, compositional relationship between meaning and syntactic form.

There is one aspect of the compositionality of natural languages, however, which much of this work has systematically neglected. Many of the ultimate meaning-carrying constituents of natural language sentences – the words and morphemes of which the sentences are made up – are ambiguous. Therefore, to interpret an incoming sentence *S* one must not only know the principles according to which the meanings of the ultimate constituents are integrated into the meaning of *S*, one must also be able to determine *which* of the different possible meanings of the ambiguous constituents are to be selected for integration into the meaning of *S*. In many contributions to natural language semantics of the past decades the focus has been on finding the compositional principles which yield the intuitively correct sentence meanings when applied to the ‘right’ word and morpheme meanings; how these ‘right’ meanings of the ambiguous words and morphemes are selected has usually been taken as given by fiat. A theory of this sort leaves it a mystery how language users normally succeed – effortlessly, it seems – in zeroing in on the correct interpretation of the sentences they hear or read.

It is clear that the linguistic knowledge a language user brings to this task consists of (i) knowledge that enables him to assign an incoming sentence a syntactic ‘parse’; and (ii) knowledge that allows him to associate with each syntactically parsed sentence a representation of its meaning. Knowledge of this second kind is generally assumed to be of two sorts: (a) knowledge of the ‘lexicon’, i.e. of the meanings of the indi-

vidual words and morphemes; and (b) knowledge of the ‘compositional’ principles which make it possible to construct a meaning representation for a sentence from its syntactic parse and lexically based information about its constituent morphemes and words. The lexicon will specify for each ambiguous word or morpheme the range of different meanings that tokens of it can have. So to arrive at the interpretation for a given sentence, the interpreter will have to select the intended meaning from the meaning ranges that the lexicon specifies for each of the ambiguous words and morphemes that the sentence contains.

In addition to the lexical ambiguities associated with their words and morphemes, many sentences are also the source of structural ambiguities – either ambiguities of the syntactic structure itself, or else ambiguities which arise when certain syntactic configurations are interpreted. (The best known examples of such structural ambiguities are scope ambiguities, which either give rise to distinct syntactic parses of the sentence or else have to be resolved in moving from syntactic parse to semantic representation in case the syntactic structure of the sentence underdetermines the order in which the meanings of different sentence constituents are to be put together.) Structural ambiguities have been the subject of explicit attention in semantic theory, but here too the focus has been mostly on identifying what the possible readings of structurally ambiguous sentence types are, and much less on how the ambiguities between them are resolved when instances of those sentence types are used in actual contexts. As we now know, disambiguation is often the effect of the ways in which ambiguities from different sources, structural and/or lexical, interact.

When one looks into disambiguating interactions more closely, one notices that disambiguation depends as a rule on some kind of conflict – some form of incoherence or inconsistency – that renders an unwanted interpretation untenable. Most combinations of meanings for the ambiguous minimal constituents of a given sentence (and/or solutions to cases of structural ambiguity) lead to some such conflict, and hence, since they cannot lead to a viable interpretation, are filtered out. In many such cases the conflict takes the form of an inconsistency in the traditional sense of deductive logic, and perhaps it is possible to analyse all relevant kinds of conflict ultimately as inconsistencies in this sense. However, the kinds of inconsistencies that have been found to play this role tend to be quite

special. In the light of this it seems a plausible assumption that human interpreters make use of special filtering mechanisms that are attuned to these particular kinds of inconsistencies, – mechanisms which are used to test for just that kind of inconsistency and which, presumably, can do that very efficiently. Similarly, it seems a reasonable working hypothesis in the context of designing computational systems for natural language interpretation that they should be equipped with purpose detectors that are attuned to just the inconsistencies of these special types.

It is in the more general context of developing a theory which deals simultaneously with the compositional synthetisation of meaning and the elimination of ambiguity that the proposals of this paper should be seen. As indicated in Section 1, these concern (a) novel representational devices, to be used both in initial sentence representations and in some of the representations into which the initial ones get transformed on the way towards the final representations; and (b) special mechanisms designed to operate on the novel representation features. We also mentioned in Section 1 that the mechanisms which operate on the initial representations not only serve to eliminate ambiguity but that they also must secure the correct ‘binding’ of the temporal variables which are introduced into the representation by various sentence constituents. Before we get down to showing the actual representations and transformation mechanisms in explicit detail, we want to say a little more about this ‘binding’ component of the theory, since it is crucial to the architecture we will be assuming. In particular, it is in its treatment of the binding of temporal variables that the present treatment differs most strikingly from earlier proposals we have made ourselves for the treatment of temporal reference within the simpler setting of DRT, in which there are no provisions for the representation and subsequent elimination of underspecification. (See [28], Ch. 5.)

As will be explained in detail in Section 3, bits of temporal information get introduced into the initial sentence representation in different places, and must then be brought into contact with each other. In particular, the eventuality variables introduced by lexical verbs must be linked with the information introduced by tense, and some kind of linking or ‘binding’ mechanism is needed for this. As it stands, this may seem to have nothing to do with questions of disambiguation. But in fact, there is a close connection. For as we will see in more detail below,

the temporal linking of eventualities can take different forms – it can be direct, as in a sentence like (1.a). But it can also be indirect, as in (1.b), where there is an interfering aspectual operator (the perfect); or as in (1.c) which contains a temporal quantifier (*oft*); or as in (1.d), where we find both.

- (1) a. *Fritz rief an.*
 “Fritz rang”
- b. *Fritz hat angerufen.*
 “Fritz has rung.”
- c. *Fritz rief oft an.*
 “Fritz rang often.”
- d. *Fritz hat oft angerufen.*
 “Fritz has often rung.”

In each of (1.b-d) the eventuality has to be linked directly to a time that is made available by the quantificational or aspectual operator; this operator is then linked in its turn to the tense information, and this link too may be either direct, as in (1.b) or (1.c), or indirect, as in (1.d).

Questions of linking become more intriguing in ambiguous sentences like (2), where the temporal adverbial *am Montag* can either be understood as referring to one particular Monday (during which Fritz rang many times), or as referring to different Mondays, all lying within the period over which *often* quantifies.

- (2) *Am Montag rief Fritz oft an.*
 “On Monday Fritz often rang.”

UDRT, in the form in which it will be used in this paper, serves on the one hand to provide unified treatments for sentences like those in (1) and (2). When such sentences are ambiguous, the UDRT formalism makes it possible to represent the ambiguity within a single UDRS; this UDRS can then be resolved to any of the DRSs which represent the different possible readings of the sentence. However, our choice of UDRT as theoretical framework is motivated not only by the structural ambiguities we find in sentences such as (1.d). As noted earlier, the most frequent source of ambiguity in natural language are lexical items and semantically relevant

morphemes such as tenses. We turn to this kind of ambiguity in Section 5, which is devoted to the different possible interpretations of the German present tense, or *Präsens*. The *Präsens* has besides its use as a “genuine present”, which expresses overlap between the described eventuality and the utterance time *n*, also a prospective use, which situates the described eventuality in the future of *n*. (In this respect the German *Präsens* differs from the English present tense, which can be interpreted prospectively only under quite special conditions, exemplified by the so-called “time table” uses of sentences like *The train arrives at 10.14*.)

Here are some examples of the kinds of present tense sentences we will consider in Section 4:

- (3) a. *Paulchen ist krank.*
 ‘Paulchen is ill.’
- b. *Paulchen kommt.*
 ‘Paulchen comes.’
- c. *Paulchen schreibt den Brief.*
 ‘Paulchen writes the letter.’
- d. *Paulchen kommt morgen.*
 ‘Paulchen comes tomorrow.’
- e. *Paulchen ist morgen krank.*
 ‘Paulchen is tomorrow ill.’
- f. *Paulchen ist morgen gesundet.*
 ‘Paulchen is tomorrow cured.’

We conclude this section by listing some of the facts concerning the possible interpretations of these sentences which will be relevant to what we will have to say about them.

(i) (3.a), when used as a complete sentence on its own, only seems to have the interpretation that Paulchen is ill at the utterance time *n*. In contrast, (3.b) only has a prospective interpretation, according to which Paulchen will arrive at some time in the future of *n*, whereas (3.c) allows for both a prospective interpretation and one which locates the writing episode as overlapping with *n*. The ambiguity of (3.c) is apparently connected with the circumstance that German does not have

an obligatory distinction between progressive and non-progressive forms. Because of this, simple tenses such as the present tense *schreibt* (lit.: writes) allow for both a progressive and a non-progressive interpretation, which English explicitly distinguishes through the use of the progressive or non-progressive form of the verb. The non-progressive interpretation of the Präsens in (3.c) goes hand in hand with the progressive interpretation of the verb phrase *schreib den Brief* (lit.: write the letter) while the prospective interpretation of the Präsens, which situates the writing episode after *n*, is linked to the non-progressive interpretation of the VP; moreover, there appears to be a preference for the first interpretation over the second. (In contrast, for (3.b), with its achievement verb *kommen*, the only possible interpretation appears to be the prospective one, presumably because progressive interpretations of German achievement verbs are hard or impossible to obtain. This difference correlates with the familiar observation that in English progressive forms of achievement verbs describe periods which precede the events described by the non-progressive forms of those verbs.)

(ii) In (3.d)-(3.f) the presence of the adverb *morgen*, which denotes a period of time disjoint from *n*, forces a prospective interpretation. That such interpretations are not only possible for these sentences but perfectly natural shows the easy accessibility of prospective interpretations for the German Präsens, as opposed to the English present tense: the English translation of (3.d) is very marked (if perhaps not outright ungrammatical), and the same goes for the English translations of (3.e) and (3.f) that we get by reversing the last two words of the given transliterations.

An interpretation theory which accounts for these facts must provide:

(a) a lexical entry for the German Präsens which makes its different possible interpretations explicit, and specify how the interpretations specified in this entry are made available as *prima facie* options for the interpretation of German sentences in which the verb bears this tense form.

(b) a mechanism, or range of mechanisms, which is/are capable of disambiguating the lexical contribution made by the Präsens, so that only those alternatives which are considered possible by a competent speaker pass the filter which the mechanism or mechanisms impose.

As regards (b), it is clear from what has been said about the examples in (3) that the disambiguation mechanisms must do justice to at least two facts that our examples made visible: first, they must be able to "coerce" the correct interpretation by checking for compatibility between particular readings of the Präsens with constraints that are contributed by other parts of the sentence (e.g. the adverb *morgen* or the aspectual properties of an achievement verb such as *kommen*); second, the prospective and non-prospective interpretations of the Präsens must be treated as ranked, in the sense that the prospective interpretation is admissible only when the non-prospective interpretation is blocked; for it is only through such a ranking that we can account for the non-existence of a prospective reading for (3.a) and for the facts relating to (3.c). (3.c) is especially interesting in this connection insofar as it illustrates a general tendency to keep marked interpretations to a minimum. Given that non-progressive non-prospective interpretations of present tense VPs like *schreibt einen Brief* are impossible (except when the present tense is used in some special way such as the reportive present, see Section 5), assigning a coherent interpretation to (3.c) requires that its tense form must be interpreted either as a progressive or as a prospective present. Both these possibilities exist (with as we noted some preference for the former option).

As we have come to see it, the principal challenge to semantic theory that virtually all sentences we discuss present is not so much that they have the meanings they have, but that it is just those meanings they have, and no others. To repeat, the problem for semantics is not simply to account for why these and other sentences mean what they do mean, but also – and more so – how meanings that they do not have, but which would have been expected on the basis of the options made available by their smallest meaningful constituents are eliminated in the process of sentence composition. We ourselves see this as a real shift in perspective, and it is one of the central points that we are anxious to get across in this paper.

The remainder of the paper is organised as follows. Section 3 introduces the basic principles of the construction algorithm. It explains the representation format of the preliminary UDRS representations and defines the unification algorithm that establishes the temporal links between 'lower' and 'higher' UDRS-components. Moreover, it looks at the

interaction of temporal locating adverbs like *yesterday* or *on Monday* with adverbial quantifiers. For reasons of space the role of information structure (more specifically focus-background articulation, see e.g. [50], [51], [2]) which was discussed in considerable detail in an earlier draft of the paper is only mentioned (in Section 3.4). We refer the reader to the forthcoming [30]. Section 4 concentrates on the interaction of the perfect operator with tense as well as non-quantifying and quantifying temporal adverbs. This completes the first Part I of this paper. Part II starts with Section 5 where we address the questions connected with the present tense mentioned earlier in Section 2. In Section 6 we discuss some of the more general issues concerning ambiguity, underspecification and disambiguation; and we extend the representation formalism of the preceding section with a new underspecification device, suited in particular for the representation of lexical ambiguities, among them the ambiguities of the German Präsens. Section 7 concerns the formal specification of the resolution algorithm for ups- and downs-variables and its place within comprehensive construction algorithm for semantic representations (from syntactic structures via UDRSs to DRSs). Section 8 compares our approach with other theories of tense and aspect.

3 Ups and downs

We proceed on the widely accepted assumption that main verbs serve to describe eventualities (that is, events or states) (cf. [28], Ch 5). Each main verb V of a clause introduces into the UDRS for that clause a variable ev (or discourse referent; we use the terms interchangeably in this paper) for the eventuality it is used to describe. Part of the information the sentence provides about ev concerns its location in time. This information may be contributed by various elements of the clause or sentence of which V is a constituent. One of these is the finite tense of V (assuming that V has finite tense). Other elements are temporal location adverbs (such as *yesterday* or *(on) Monday*), frequency adverbs (such as *often* or *never*) and aspectual operators like the perfect or the progressive. When more than one such element is present, the total location information about ev results from the ways in which the constraints imposed by these different sources interact. One of the aims of this paper is to specify these constraints in such a way that the interactions are

predicted correctly.

As announced in Section 1, the framework within which we will formulate these specifications is that of UDRT (see [48], [49]). The general architecture and principles of UDRT will play an important part in our account of how the different constraints interact and how they can be resolved. But in addition we will need principles that deal specifically with the processing of temporal information. These principles are all concerned with the “management” of “temporal variables”, i.e. variables which either range over eventualities or over instants and periods of time. An important part of this “temporal variable management” are the rules which govern the unification of two types of temporal variables, the “ups-variables”, marked by an upwards pointing arrow, and the “downs variables”, marked by an arrow pointing downwards. Since the ups- and downs-variables which are unified with each other always belong to different components of the initial UDRS, and unification entails merging of the UDRS components to which the unified variables belong, unification of temporal variables is an important factor in the transition from the initial UDRS to a specified representation (i.e. a DRS).

The basic case, from which the general unification procedure has been developed, is given by simple tensed sentences like (4).

- (4) *Paulchen gewann.*
 “Paulchen won.”

We assume that the initial UDRS for this sentence (as for all other sentences) is constructed from a syntactic representation in which the information connected with tense is located at a node that is at some distance from the node of the lexical verb, and which dominates the latter (in the sense familiar from generative syntax; we refer to the former node as I(NFL), and to the latter one as V). Suppose that (4) has the syntactic analysis given in (5).

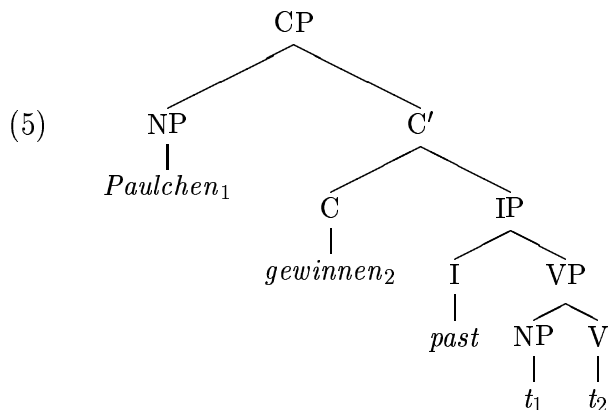

The construction procedure will at first associate with the INFL node of this representation, with its V node and with its subject node the part representations shown in (6). As said, the verb at V introduces a variable ev for the eventuality it describes, together with a variable \uparrow_t for its location time and a relation between the two which captures the nature of the location (“ $ev \subseteq \uparrow_t$ ” in case ev is an event and “ $\uparrow_t \subseteq ev$ ” in case it is a state (viz. [6], [54])). (In the case of our example, where the verb is the event verb *gewinnen* (*win*), we get the relational condition “ $e \subseteq \uparrow_t$ ”, where e represents the event of Paulchen winning). INFL introduces a discourse referent \downarrow_t that is related to the speech point n . The down-arrow indicates that this discourse referent is a potential binder for a variable of the type \uparrow_t introduced by the verb at node V; we will come back to this shortly. In the present example the tense is the “Präteritum” (corresponding roughly to the English simple past) and the information connected with \downarrow_t is given by the condition “ $t_t < n$ ”, expressing that the time denoted by t_t lies before the utterance time n , which is given by the lexical entry for *past*. (We assume that this is the only “reading” which the entry for *past* specifies.) The proper name *Paulchen* contributes a part representation that is marked with *prop.name*. This representation is an abbreviation for a more complex set of conditions which capture the contributions which proper names make to the sentences in which they occur. (This contribution involves, like the contributions of all other definite NPs, a presupposition that the referent can be identified in some appropriate way in the context in which the sentence is uttered.) In this paper we bypass the details and simply assume that the final result of a name’s interpretation is always a representation of its referent at the

highest possible level of the semantic representation of the discourse of which the sentence containing the name is part.

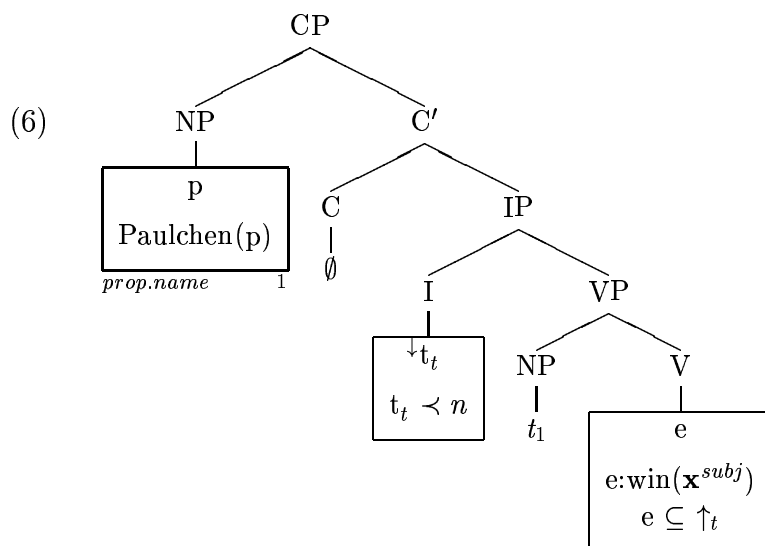

Note that we have ‘reconstructed’ the verb into its base position by interpreting its argument (the subject NP *Paulchen*) at the site to which it has moved. This reflects the intuition that the predication whose predicate is the verb is always at the bottom of the UDRS into which such a decorated tree can be converted, whereas the surface position of argument phrases often indicates the scope relations in which they stand to other parts of the sentence.

Independent of the question whether the verb and its arguments are interpreted in their base positions or the positions to which they have moved is the question of argument instantiation. Intuitively, it is clear that it ought to be part of integrating the different semantic components of (6) into a single representation for the sentence that the ‘subject’ variable \mathbf{x} in the semantic representation of *gewinnen* is instantiated by the discourse referent p for the subject phrase. The instantiation of \mathbf{x} by p rests on two bits of information: (i) the fact that the NP *Paulchen*, whose referent p represents, is the subject phrase of the sentence (and thus fills that argument slot of the verbal predicate which is syntactically realised as subject phrase); and (ii) the fact that the argument of *gewinnen* which is marked as \mathbf{x} is to be filled by the grammatical subject of the sentence (in case the verb is used in the active voice; for details see [32] and [18]).

In (7) the part representations of (6) have been put together into a UDRS. The ordering between the components of this UDRS reflects the following principles: (i) the contribution made by the V constituent of the syntactic structure is ordered below the representation of each of the verb's arguments (here there is exactly one such, viz. the subject); and (ii) the information attached to I (and contributed by tense) is not below any other constituent in the order.¹ Note well that the edges of UDRS-diagrams like (7) represent a weak ordering: the upper one of the two components connected by an edge may end up in a genuinely higher position than the lower one in the final representation derived from the UDRS, but it is also possible for the two components to get merged. In the case of (7) this is what happens for both of its edges (see (8)).

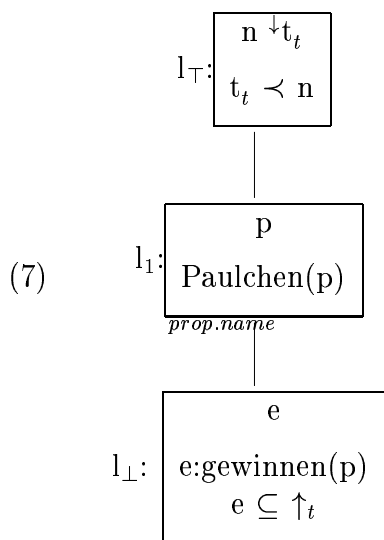

The partial ordering of the components will constrain the possible unifications of the ups-variables $\uparrow t$ and the downwards pointing discourse referents of the form $\downarrow t_t$. In the case at hand only one such unification is possible: $\uparrow t$ must be unified with a matching variable $\downarrow t_t$ that is introduced by tense at INFL. Unification of $\downarrow t_t$ with $\uparrow t$ yields the condition that the event e (of Paulchen winning) occurred at some time before the speech time. The downwards pointing arrow will be eliminated once the unification has been carried out. The final result is given in (8). (From

¹We will always assume that the discourse referent n representing ‘now’ is declared at the top level UDRS-component, i.e. belongs to the universe of this component.

now on we will for the most part limit ourselves to presenting stages in the representation construction corresponding to (7), (8) and, when appropriate, intermediate stages between these, but refrain from showing fully or partially decorated syntactic trees.)

$$(8) \quad \boxed{\begin{array}{c} n \ t_t \ e \ p \\ \text{Paulchen}(p) \\ t_t \prec n \\ e:\text{gewinnen}(p) \\ e \subseteq t_t \end{array}}$$

N.B. As usual in UDRT, the components of the UDRS (7) have each been given a label. l_{\top} and l_{\perp} are used to label the highest and the lowest component of the UDRS, respectively; this implies that all components stand in the relation \leq to l_{\top} and in the relation \geq to l_{\perp} . Further processing of a UDRS will often have the effect that its partial order is strengthened. One instance of such a strengthening is the one triggered by the presuppositional feature *prop.name* of the part representation labelled l_1 in (7). This feature yields identification of l_1 with l_{\top} . Other instances are connected with the resolution of structural ambiguities, and in particular with those processing steps which involve unification of temporal variables. Thus the unification which leads from (7) to (8) above has the effect that the components labeled with l_{\top} and l_{\perp} are merged. (The given condition set $\{l_{\perp} \leq l_1, l_1 \leq l_{\top}\}$ is extended to the set $\{l_{\perp} \leq l_1, l_1 \leq l_{\top}, l_1 \leq l_{\perp}, l_{\top} \leq l_1\}$.) For details see [48] and Section 8 below.)

To go from (5) to (6) we need semantic specifications for each of the three “lexical items” occurring in (5) – the verb *gewinnen*, the Präteritum attached to INFL and the proper name *Paulchen*. We already mentioned that the ultimate result of a name’s interpretation is always a representation of its bearer at the highest possible level. But we need to say something more about the lexical entries of the verb and the tense. A first, simplified entry for the verb *gewinnen*, which will be adjusted below under (13), is given in (9).

$$(9) \quad \textit{gewinnen} \quad \rightsquigarrow \quad \boxed{\begin{array}{c} e \\ e:\text{gewinnen}(\mathbf{x}^{subj}) \\ e \subseteq \uparrow_t \end{array}}$$

Here the bold face \mathbf{x}^{subj} serves as a place holder for the argument of *gewinnen* which is supplied by the subject NP of the clause of which *gewinnen* is the main verb. The actual supplying takes place only when the representation of the verb is combined with that of the subject NP; at that point the place holder \mathbf{x}^{subj} gets replaced by the discourse referent p which represents the subject's denotation.

For the three “simple tenses” of German – the Präsens (present tense), Präteritum (simple past) and Futurum (the simple future tense) we start by adopting the lexical entries in (10). According to (10) the Präteritum locates the eventuality described by its verb in the past of the utterance time n , the Präsens locates it as including n , and the Futurum as being located after n . (Note well that these entries represent considerable simplifications of the semantic characterisations of these tenses that are needed to cover the full range of their possible uses; but they will do for our immediate purpose. We will return to the semantics of the Präsens in Sections 5 and 6, where we will adopt an entry that also covers those uses in which it refers to past or future times.)

$$(10) \quad \text{TENSE} = \begin{array}{ccc} \textit{past} & \textit{pres} & \textit{fut} \\ \begin{array}{|c|} \hline \downarrow t_t \\ \hline t_t < n \\ \hline \end{array} & \begin{array}{|c|} \hline \downarrow t_t \\ \hline t_t = n \\ \hline \end{array} & \begin{array}{|c|} \hline \downarrow t_t \\ \hline n < t_t \\ \hline \end{array} \end{array}$$

3.1 Temporal Unification and Temporal Locating Adverbs

(4) is an exceptionally simple sentence in that the information about the temporal location of the event e described by the verb comes from only one source, viz. the past tense. A first complication arises with sentences in which temporal location is further constrained by a locating adverb, such as *gestern* (*yesterday*) in (11):

- (11) *Gestern gewann Paulchen.*
 “Yesterday Paulchen won”.

Construction of the semantic representation of (11) must do justice to the requirement that the time designated by the adverb imposes an additional constraint on the location of e .

There is more than one way in which one might think such adverbial constraints could be incorporated into the formalism we have developed so far, and we have no conclusive argument that the one we have chosen is the only one possible. Perhaps the first option that comes to mind is to identify the denotation of the adverb with the downs variable $\downarrow t_t$ contributed by tense. This, however, leads to problems in cases where a present tense combines with adverbs like *today*, *this week* etc., whose denotations include the utterance time but extend substantially beyond it. Given our characterisation of the present tense as contributing the condition “ $\downarrow t_t = n$ ”, this leads to a conflict if we assume that n represents the utterance time. For instance, it would force us to identify the utterance time of a present tense sentence containing the adverb *today* with the entire day on which the utterance is made. So, it would force us to give up the idea that n always stands for the utterance time in any intuitively plausible sense of the term. More seriously, it would prevent us from getting consistent interpretations for sentences like *Paulchen gewann heute*. (“Paulchen won today.”) and *Paulchen wird heute gewinnen*. (“Paulchen will win today.”) given the assumptions about past and future tense made in (10). The alternative would be to replace the condition “ $\downarrow t_t = n$ ” introduced by the present tense by the weaker condition “ $n \subseteq \downarrow t_t$ ”. But this second alternative has its unwanted consequences too. In particular, a present tense sentence like

- (12) *Paulchen kommt heute*.
 “Paulchen comes today.”

will now be true as long as an event of Paulchen’s coming is included within the day on which it is uttered. So, in particular, (12) is predicted to be true if Paulchen came on the day of the utterance time n at some time preceding n , and that is clearly at variance with what (12) means.² So in order to stave off this undesirable effect, other changes would have to be made. We have no proof that this would be impossible, but we do not see how this could be done.

The considerations of the last paragraph also argue against an account of the interaction between tense and temporal adverb in which each in-

²Even worse, a present tense sentence without a temporal adverb, such as the simple *Paulchen kommt*., would now impose no constraint on the time of Paulchen’s coming whatsoever.

roduces its own downs variable, but in which both are allowed to unify with the same ups-variable \uparrow_t introduced by the verb. For obviously that too would have the effect that the denotation of the adverb and \downarrow_t are identified.

To avoid this last difficulty we assume not only that tense and adverb each introduce their own downs-variable but also that each of these unifies with a distinct ups-variable. More specifically, we assume that the eventuality introduced by the verb comes with a double location requirement, the old requirement that its location be governed by tense, which we still represent by means of the ups-variable \uparrow_t , and a further location requirement, represented by a new variable \uparrow_{loc} . In sentences with temporal adverbs the unification requirement represented by \uparrow_{loc} can be satisfied through unification with the downs-variable introduced by the adverb. In sentences without such adverbs \uparrow_{loc} cannot be resolved in this way and in such cases the resolution will depend on the context in which the sentence is used.³

It is clear that in general \uparrow_t and \uparrow_{loc} should not be identified; for then we would be back with the difficulties explained above. However, we assume that they always stand in the relation $\uparrow_t \subseteq \uparrow_{loc}$. The intuition behind this is that \uparrow_t is still to be considered as representing the location time of the described eventuality. \uparrow_{loc} serves to identify the position of this location time along the time line more closely, by requiring it to be included in the interval which it ends up representing after unification.

We already saw that the relation between the eventuality ev and its location time depends on whether ev is an event or a state – if ev is an event, then $ev \subseteq \uparrow_t$, and if ev is a state, then $\uparrow_t \subseteq ev$. Now that we have introduced \uparrow_{loc} , a similar question arises with regard to ev and it. For events the matter has already been settled by the assumptions we have made: $ev \subseteq \uparrow_t \subseteq \uparrow_{loc}$. But not so for states. In the literature on tense and aspect two proposals are prominent. According to the weaker one all that can be said in general about the relationship is that state and

³In the case of past tense sentences this requirement matches the intuition that such sentences tend to sound odd unless the context makes it possible to locate the described eventuality more closely. (Cf. the tendency to add “dummy adverbs” like *once upon a time* when no real restriction is intended. See [17] and [57].)

With future tense sentences this sense of oddity is not as strong. We suspect that this is connected with the modal dimension of the future. For present tense sentences there is a default resolution of \uparrow_{loc} to n .

\uparrow_{loc} overlap; according to the stronger one the latter is included in the former. A perusal of state-describing sentences with temporal adverbs shows that both possibilities occur. So what one would want eventually is a more refined theory, which distinguishes between those cases where inclusion holds and those where there is overlap but no inclusion. Such a theory is beyond the grasp of the present proposal. We have opted for the simplifying assumption that when *ev* is a state, then it always includes \uparrow_{loc} .

These assumptions are exemplified in the lexical entries for the event verb *gewinnen* (*win*) and the state verb *schlafen* (*be asleep*).

$$(13) \text{ gewinnen} \rightsquigarrow \boxed{\begin{array}{c} e \\ e:\text{gewinnen}(\mathbf{x}^{subj}) \\ e \subseteq \uparrow_t \subseteq \uparrow_{loc} \end{array}} \quad \text{schlafen} \rightsquigarrow \boxed{\begin{array}{c} s \\ s:\text{schlafen}(\mathbf{x}^{subj}) \\ \uparrow_t \subseteq \uparrow_{loc} \subseteq s \end{array}}$$

(14) gives the entry for the adverb *gestern*.

$$(14) \text{ gestern} \rightsquigarrow \left\langle \left\{ \begin{array}{c} t' \ t'' \\ \text{day}(t') \\ \text{day}(t'') \\ n \subseteq t' \\ t'' \supseteq t' \end{array} \right\}, \boxed{\begin{array}{c} \downarrow t_{loc}^g \\ t_{loc}^g = t'' \end{array}} \right\rangle$$

The component to the right in (14) is typical for the representations of temporal adverbials in general. This component introduces the down-variable $\downarrow t_{loc}^g$ which in the case of (11) will unify with the \uparrow_{loc} introduced by the verb *gewinnen*. It represents the time which is provided by the temporal adverb *gestern*. The use of *gestern* as an adverb must be distinguished from its uses as NP, as we find it, e.g., in *Gestern war ein schöner Tag*. (Engl.: *Yesterday was a beautiful day*). We analyse the adverb *gestern* as a prepositional phrase with silent preposition and an occurrence of *gestern* as NP which is governed by this preposition. The discourse referent t'' in (14) represents the referent of this NP, and the silent preposition expresses identity – much like the English temporal

preposition *on* – and its contribution to (14) is the identity condition $t_{loc}^g = t''$.⁴

The component on the left in (14) is a presupposition to the component on the right. It is the presupposition which the NP *gestern* introduces in virtue of its being a definite noun phrase.⁵ But it is a presupposition whose satisfaction will be guaranteed in any normal utterance situation. It requires there to be a (unique) day which immediately precedes the day on which the utterance is made, and so long as the utterance is made on some particular day this requirement will be fulfilled. The upshot of this is that the presuppositional component of (14) can be added as a non-presuppositional part to the representation of a sentence in which *gestern* occurs (cf. (15.a)).

In the same way as we derived (7) from the decorated syntactic structure of (6) of (4), we get for (11) the representation in (15.a), which after justification of the presuppositions of *Paulchen* and *gestern* turns into (15.b):

⁴Note that although the discourse referent t' is declared in the universe of the presupposed DRS it will not be a possible antecedent for anaphoric expressions and must therefore be classified as “implicit”. Since this paper doesn’t deal with questions of extra-sentential anaphora, we use no notation which distinguishes between anaphora-accessible discourse referents like t'' and non-accessible variables like t' (viz. [32]).

⁵We assume that every type of definite NP comes with a presupposition to the effect that its referent can be determined on the basis of independent information in a manner that is appropriate for that type (viz. [21], [22], [19], [18]).

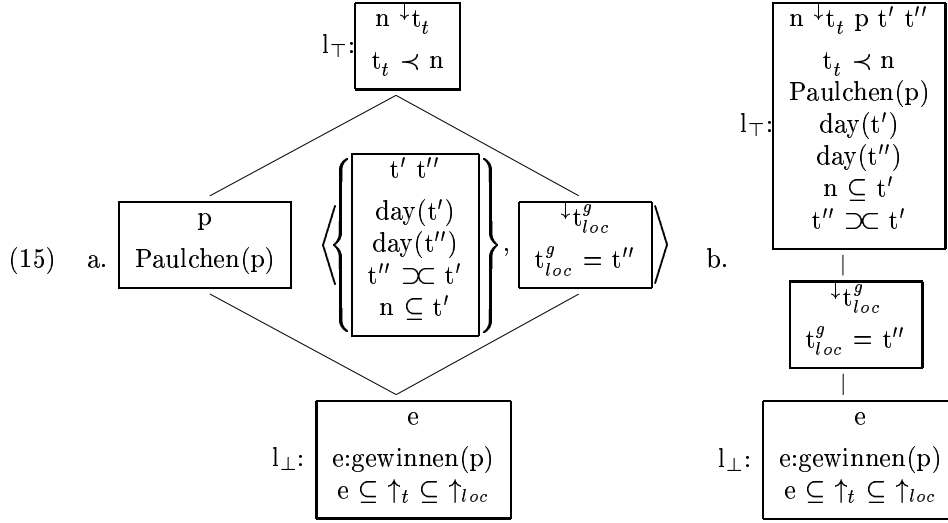

Unification of \uparrow_t with $\downarrow t_t$ and \uparrow_{loc} with $\downarrow t_{loc}^g$ turns (15.b) into the DRS (16).

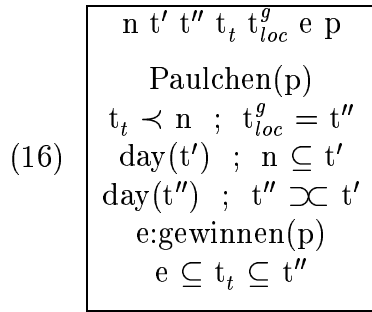

3.2 Temporal Quantifying Adverbials

In the examples considered so far the ups-variables introduced by the verb (and thus belonging to the UDRS-component l_{\perp}) were bound by the downs-variables introduced by tense and by adverbs like *gestern* or *heute*. In general, there will be other candidates for the bindings of these ups-variables as well. In particular such binders are made available by temporal adverbial quantifiers and aspect operators such as the perfect. We look at the case of adverbial quantifiers in this section and at the perfect and its interaction with adverbial quantification in Section 4.

When several such binders are present within a given sentence, the question which of them will bind a given ups-variable will depend in

part on the hierarchical relations between the components of the initial UDRS to which the sentence gives rise. Adverbial quantifiers such as *oft* (*often*) introduce their own components into the UDRS.⁶ In our present treatment of *oft*, the central constituent of this component is a duplex condition whose middle component is the actual quantifier denoted by the adverb and whose restrictor and nuclear scope, on its left and right, respectively, must be filled with material that is to be supplied by other parts of the sentence (and, as regards the restrictor often, also by the context in which the sentence is used). This can be seen in (17), which gives the non-presuppositional part of the semantic representation that *oft* contributes to the UDRSs of the sentences in which it occurs. We further assume that *oft* introduces a “quantificational state” s^{oft} . This state is characterised by the condition that the quantification holds when restricted to its duration – more explicitly, the relation denoted by the quantifier should hold between (i) the set of relevant satisfiers of its restrictor which lie within this duration and (ii) the subset of this set consisting of the satisfiers of its nuclear scope.

Note that the duration of a quantificational state is often completely specified by an accompanying adverb. For instance, the force of *gestern* in (18) is that it was the period it denotes, i.e. the day before that of the speech-time, which is characterised by the fact that Paulchen often won. In particular the duration of the quantificational state is *just* the denotation of the adverb and not some larger interval properly including this denotation.⁷ This means that the temporal relation which we assume to hold generally between states and their location times, viz. that the latter are temporally included in the former, is insufficient for states of this particular, quantificational, sort. The best way to capture this further constraint is to require that the duration of a quantificational state be the same as \uparrow_{loc} . To this end we strengthen the condition “ $\uparrow_t \subseteq \uparrow_{loc} \subseteq s^{oft}$ ” to “ $\uparrow_t \subseteq \uparrow_{loc} = s^{oft}$ ”. (Strictly speaking the use of “=” isn’t quite right. What is intended is that the *duration* of s^{oft} is identical with \uparrow_{loc} , not the state s^{oft} itself. So a more correct notation would be $\uparrow_{loc} =$

⁶In this paper we only consider the interpretation of *oft* as proportional quantifier, ignoring its interpretation as “cardinality quantifier” (viz. [45]).

⁷Suppose for instance that on the whole Paulchen had many wins during the past three days, but that none or only few of those took place yesterday. Then (18) would be judged false while the sentence we get by replacing *gestern* by *die letzten drei Tage* (the last three days) would be acceptable as true.

$dur(s^{oft})$, where for any eventuality ev $dur(ev)$ is the temporal interval covered by ev . We use the sloppy notation.)

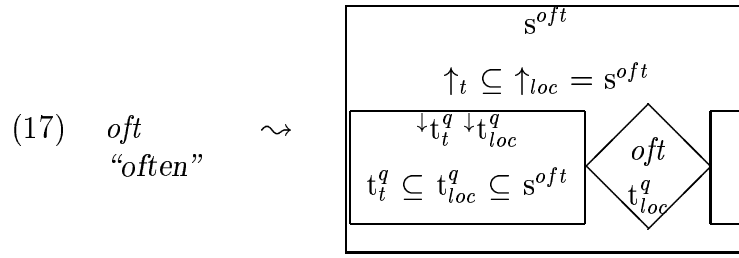

(19) shows the stage of UDRS-construction for (18) before unification of ups- and downs-variables takes place.

- (18) *Paulchen gewann gestern oft.*
 'Paulchen won yesterday often.'
 "Yesterday Paulchen often won."

(19)

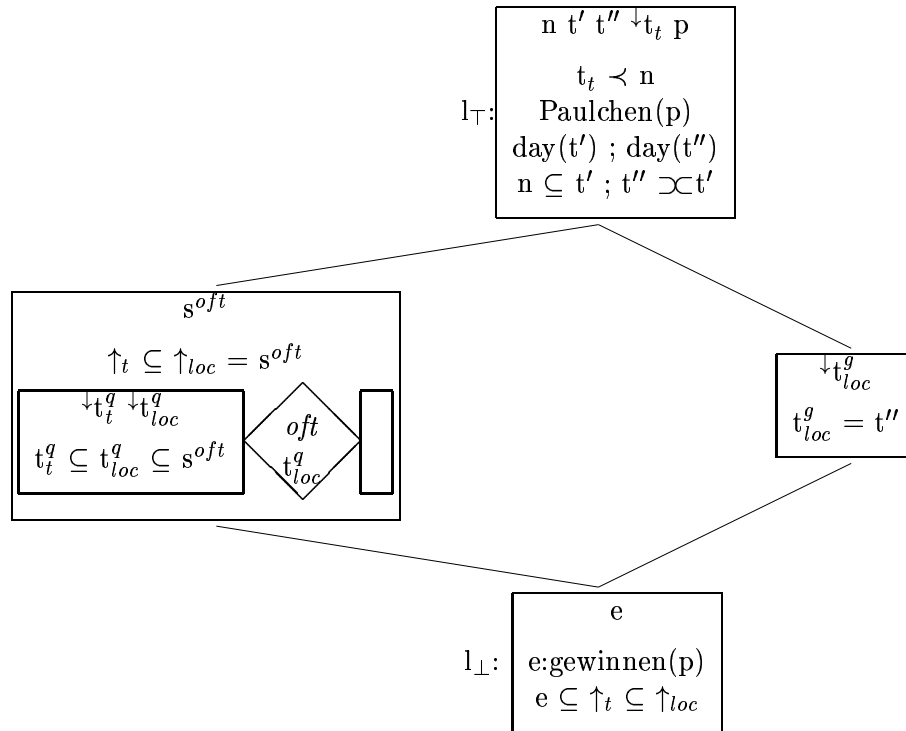

In (19) the presupposition of the part representation for the proper name *Paulchen* as well as the presupposition of *gestern* have already been justified and their contributions have been incorporated into the top level component l_{\top} . Instantiation of the ups- and downs-variables in (19) will produce a strengthening of the UDRS ordering, to the effect that the part representation containing the downs-variable $\downarrow t_{loc}^g$ is either given wide or narrow scope wrt. the quantification. The structure on the left hand side in (20) represents the case where unification of $\downarrow t_{loc}^g$ has not yet taken place but the adverbial contribution of *gestern* has been assigned wide scope, i.e. it is merged with the DRS component l_{\top} ; similarly, in the right hand side structure this contribution has been given narrow scope and it has moreover been assumed to contribute to the restrictor of the quantifier. We will discuss cases where an adverb contributes to the nuclear scope of a quantifier in [30].

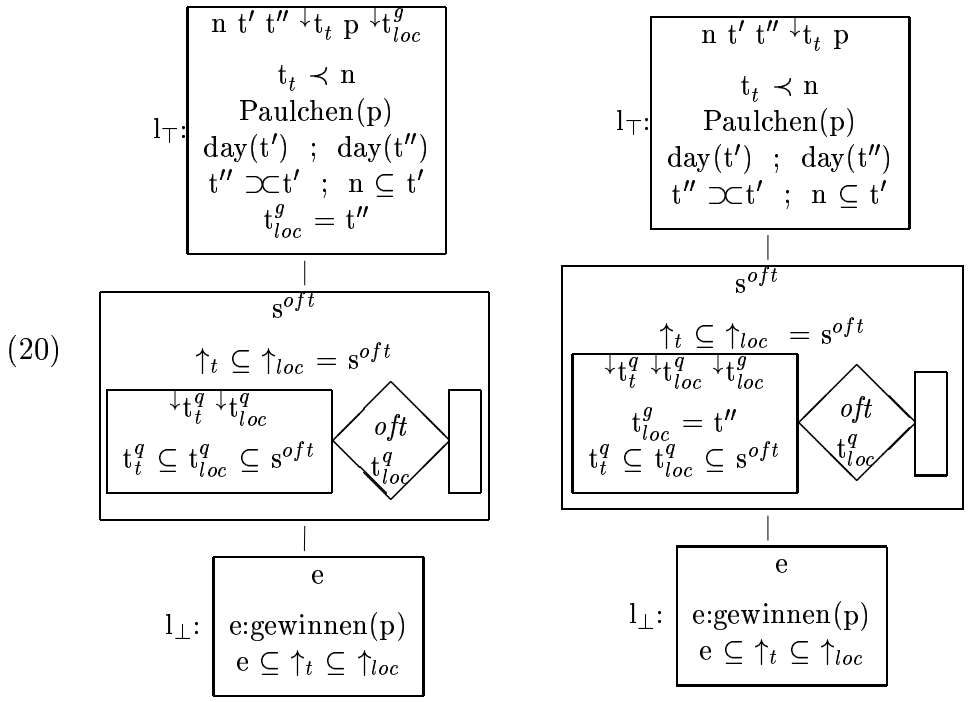

As there is no structural ambiguity left in either of the representations of (20), the unification of the ups- and downs-variables is uniquely determined in each case. We start with the structure on the left hand side. The unification algorithm is most easily described as proceeding

bottom-up. The ups-variables \uparrow_t and \uparrow_{loc} occurring in the bottom box must be matched with the first accessible downs-variables one encounters going up. In the structure on the left hand side of (20) the first accessible downs-variables are the ones declared in the restrictor of the duplex condition. Likewise the ups-variables in the representation of *oft* will be matched with the closest accessible downs-variables \downarrow_t and \downarrow_{loc}^g . These instantiations yield the interpretation in (21), according to which all the winning events took place yesterday.

$$(21) \quad \boxed{\begin{array}{c} n \ t' \ t'' \ t_t \ t_{loc}^g \ p \ s^{oft} \\ \\ t_t \prec n \\ \text{Paulchen}(p) \\ \text{day}(t') \ ; \ \text{day}(t'') \\ t'' \supseteq t' \ ; \ n \subseteq t' \\ t_{loc}^g = t'' \\ t_t \subseteq t_{loc}^g = s^{oft} \\ \\ \boxed{\begin{array}{c} t_t^q \ t_{loc}^q \\ t_t^q \subseteq t_{loc}^q \subseteq s^{oft} \end{array}} \quad \diamond \quad \begin{array}{c} e \\ \text{e:gewinnen}(p) \\ e \subseteq t_t^q \subseteq t_{loc}^q \end{array} \end{array}}$$

The structure on the right hand side of (20) is different in that there are two possible binders, \downarrow_{loc}^q and \downarrow_{loc}^g , for the ups-variable \uparrow_{loc} occurring in the bottom box. Where two \downarrow_{loc} -variables belong to the universe of the same compound of the representation the unification requirements may be satisfied by identifying them both with the same \uparrow_{loc} -variable.⁸ For the case of (21) this results in the identification of \downarrow_{loc}^q and \downarrow_{loc}^g , as shown in (22). (We record the identification by adding the condition “ $t_{loc}^q = t_{loc}^g$ ” to the DRS whose universe contains the two downs-variables, rather than by replacing one of them by the other.)

⁸This possibility only exists for variables of type ‘loc’. For variables of type ‘t’ unification is always one-to-one. See Section 7.

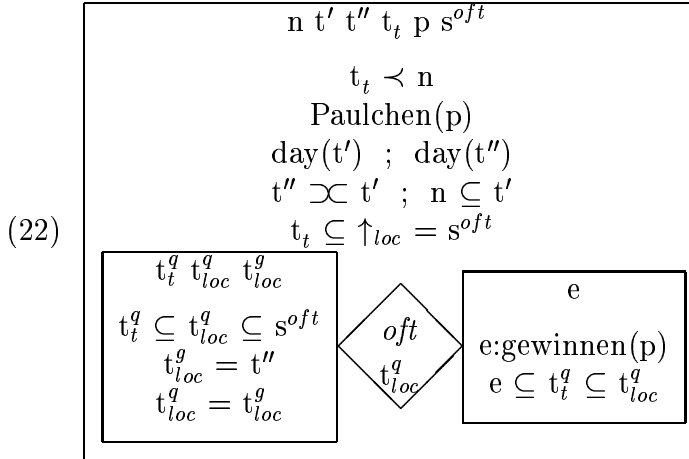

Note that the identification of t_{loc}^q with t_{loc}^g results in a violation of a familiar principle, to which we will refer as *quantificational variety*. The identification of the quantified variable t_{loc}^q with the discourse referent t_{loc}^g representing *gestern* restricts the possible values of the quantified variable to a single one, viz. the day preceding that of the utterance time. Such quantifications are odd. The conditions in the restrictor ought to be weak enough to make it possible for the quantified variable to adopt more values than just one. (22) is ruled out because it violates this principle.

(Principle of Quantificational Variety)

Natural language quantifications presuppose that their restrictors do not entail that they can be satisfied by at most one value for the quantified variable.⁹

3.3 Temporal Quantification without Locating Adverbs

A problem arises for sentences like (23) in which there is no adverb to bind the \uparrow_{loc} contributed by the entry (18) for *oft*.

⁹This formulation is somewhat loose in so far as we do not say exactly what is meant by “entail” here. In the case at hand it is intuitively clear what a case of entailment we are dealing with: the condition $t_{loc}^q = t'$, where t' is bound outside the duplex condition clearly entails that t' is the only possible value for t_{loc}^q , on any reasonable definition of entailment.

(23) *Paulchen rief oft an.*

As mentioned before, in such cases the ups-variable acts as an anaphoric presupposition that must be resolved in context. As things stand, however, there is nothing which prevents a resolution of \uparrow_{loc} to some interval which straddles n . This would entail that the quantification state s^{oft} would straddle n too. This would then permit calls after the speech time n to be taken into account in the evaluation of (23), which is evidently in disagreement with the way we understand (23): Clearly (23) is only about telephone calls in the past of n .

A similar problem arises in connection with sentences like (24), in which the adverb *heute* apparently refers to an interval of time which does not lie before n but includes it.

(24) *Heute rief Paulchen oft an.*

In both cases the effect of the past tense is to limit the temporal quantification range to the past.

To capture this we have to revise the preliminary entry for the past tense we presented in (10), and similarly the entries for the present and future tense. (To deal with (24) we need in addition special provisions in connection with the lexical entry for *heute*. See Section 6.) Quantificational sentences like those considered in this section throw a new light on the function of these three tenses: past tense sentences with adverbial quantifiers like the examples we have looked at locate the entire range of quantification in the past of n , quantificational sentences in the future tense locate it entirely in the future of n , while present sentences imply that the range of quantification includes n . This assessment equally applies to non-quantificational sentences – like those considered in Section 3.1 – but it is only the quantificational case which requires the particular formulation we have just given.

To capture the role of the tenses just described in the formal setting developed here it is necessary to allow the tenses to exert their influence not only on \uparrow_t but also on \uparrow_{loc} . Given the assumptions we have already made, the natural way to achieve this is to let the tenses not only introduce a downs-variable \downarrow_t but also a variable $\downarrow_{t_{loc}}$ and to impose their restriction on this second variable as well.

(25) (Revision of the lexical entries in (10) for the past, present and future tense)

$$\text{TENSE} = \begin{array}{ccc} \textit{past} & \textit{pres} & \textit{fut} \\ \boxed{\begin{array}{c} \downarrow t_t \downarrow t_{loc} \\ t_t \subseteq t_{loc} \prec n \end{array}} & \boxed{\begin{array}{c} \downarrow t_t \downarrow t_{loc} \\ n = t_t \subseteq t_{loc} \end{array}} & \boxed{\begin{array}{c} \downarrow t_t \downarrow t_{loc} \\ n \prec t_t \subseteq t_{loc} \end{array}} \end{array}$$

It is also easy to see that sentences like (23) and (24) now get interpretations in which the state s^{oft} is located before n . Furthermore, sentences like (4), (11) or (12) get essentially the same interpretations that they receive when the tenses are assumed to have the entries in (10). For instance, the DRS for (11) now becomes:

$$(26) \quad \boxed{\begin{array}{c} n \ t' \ t'' \ t_t \ t_{loc} \ t_{loc}^g \ e \ p \\ \text{Paulchen}(p) \\ t_t \prec n \ ; \ t_{loc} = t'' \ ; \ t_{loc} = t_{loc}^g \\ \text{day}(t') \ ; \ \text{day}(t'') \ ; \ n \subseteq t' \ ; \ t'' \supseteq t' \\ e: \text{gewinnen}(p) \\ e \subseteq t_t \subseteq t'' \end{array}}$$

The only difference between (26) and the earlier DRS (16) is that (26) contains the variable t_{loc} , which is identified with t_{loc}^g because both $\downarrow t_{loc}$ and $\downarrow t_{loc}^g$ have been unified with the ups-variable \uparrow_{loc} provided by the verb of (11). In fact, t_{loc} is redundant in (26). This is just as expected, for the adverb *gestern* guarantees that \uparrow_{loc} (and thus t_{loc}) coincide with it and therefore are situated before n . A similar redundancy arises when we use (25) instead of (10) in the representation construction for (18).

There is, however, a slight difference between the interpretations that (10) and (25) give us for (4). If the representation for (4) is constructed on the basis of the entry (13) for *gewinnen* and the entry (10) for the past tense, the ups-variable \uparrow_{loc} introduced by *gewinnen* cannot be unified with a downs-variable. As noted, such unmatched ups-arrows can be seen as presupposition-like requirements on the context to provide a suitable value for the ups-variable. In contrast, when the DRS is constructed according to (13) and (25), then \uparrow_{loc} is unified with the downs-variable $\downarrow t_{loc}$ introduced by the past tense and no resolution requirement remains. It could be argued that the first representation is preferable since past

tense sentences without temporal locating adverbs do seem to require locating support from the context. We can add an anaphoric presupposition on $\downarrow t_{loc}$ to the entries for the tenses. For instance, this would transform the entry for the past tense in (25) into

$$(27) \left\langle \left\{ \begin{array}{c} \underline{\downarrow t_{loc}} \\ t_{loc} < n \end{array} \right\}, \begin{array}{c} \downarrow t_t \\ t_t \subseteq t_{loc} \end{array} \right\rangle$$

(The underlining of the discourse referent $\downarrow t_{loc}$ in the universe of the presupposition indicates that the resolution of the presupposition must provide a value for it. Since it is a constraint on resolution that this value lies before n we have added the condition ' $t_{loc} < n$ ' to the presupposition. Since it is part of the presupposition, it is no longer required as part of the non-presuppositional component.)

Resolution of the presupposition in (27) can take two forms. In cases where $\underline{\downarrow t_{loc}}$ unifies with an ups-variable \uparrow_{loc} jointly with some adverbial downs-variable, then the two downs-variables are set equal and this can be regarded as a sentence-internal resolution of the presuppositional constraint on $\underline{\downarrow t_{loc}}$. If $\underline{\downarrow t_{loc}}$ unifies on its own, then the presupposition has to be resolved in some other way, either by deriving a value for $\underline{\downarrow t_{loc}}$ from the wider context or by accommodation.

In this paper we will make do with the simpler entries given in (25).

3.4 A Scopally Ambiguous Locating Adverb: *am Montag*

In contrast to *yesterday* locating adverbials like *am Montag* can be interpreted as contributing to the restrictor of a quantificational adverb without contradicting the principle of Quantificational Variety. Consider (28).

- (28) *Paulchen gewann am Montag oft.*
'Paulchen won on Monday often.'

Besides a reading which corresponds to the interpretation (21) of (18) – on the particular Monday referred to by the phrase *am Montag* there were many occasions when Paulchen won – (28) also has an interpretation in which *am Montag* has narrow scope with respect to the frequency

adverb *oft*. On such an interpretation the period of time over which the quantification expressed by *oft* ranges – i.e. the period of time we have indicated in (17) as s^{oft} – must be one within which the adverbial *am Montag* can pick out more (preferably substantially more) than one referent; in other words, s^{oft} should include several different Mondays. Exactly what interpretation (28) gets in case *am Montag* is taken to have narrow scope wrt. *oft* will then still depend on further factors, which have to do with information structure. Taking *am Montag* to be the focus of the clause will give rise to the interpretation that within the period denoted by s^{oft} many of the occasions when Paulchen won were on a Monday. In this case the condition of there being an event e of Paulchen winning within t_{loc}^q , where t_{loc}^q is the variable bound by the quantifier expressed by *oft*, will be part of the restrictor of the quantifier, and the condition that e occurred on the Monday within t_{loc}^q will constitute the nuclear scope. (This interpretation implies that the quantification is over periods t_{loc}^q each of which contains exactly one Monday, e.g. over calendar weeks.)¹⁰ A second interpretation with narrow scope of *am Montag* is that within s^{oft} there were many Mondays on which Paulchen won. In this case the information that the time was a Monday is in the restrictor and the information that it was the time of an occasion when Paulchen won is in the nuclear scope. Our discussion of (28) will focus on the last of the three readings mentioned, in which *am Montag* becomes part of the restrictor of *oft* and the verbal predication part of its nuclear scope. We will ignore the other narrow scope interpretation for *am Montag* as well as the role of information structure in deciding between that interpretation and the one we will consider. These issues will be discussed in [30].

The possibility of narrow scope interpretation of *am Montag* is due to the fact that the presupposition of the definite NP *der Montag* allows for a reading that depends on the value of the quantified variable. We adopt the “neo-classical” treatment of singular definite descriptions according to which each description comes with an existence-and-uniqueness presupposition (cf. [23], [26], as well as the hints in [28], Ch. 3). The account

¹⁰The reading just described is a little easier to get when *am Montag* is at the end of the sentence, as in *Paulchen gewann oft am Montag*. This is in keeping with what we know about the way in which focus is realised in German (as well as, in this case, in English). To get this reading for (28) itself seems to require special stress on *am Montag*; again this is consistent with what is known about focus realisation.

is “neo-classical” in that the predicate of which a unique satisfaction is claimed contains besides the descriptive content of the NP an explicit, contextually resolvable predicate C .

When a definite description is time-denoting, the restricting predicate often takes the form of determining temporal bounds within which the descriptive content is uniquely instantiated. In the case of the description *der Montag* this frame must be large enough to include a Monday, and it must not be in excess of 13 days, for then it would contain at least 2 Mondays and hence not a unique one. In typical cases it will be something like a week. In the ‘lexical entry’ for the phrase *der Montag* given in (29) we have accounted for this special, frame-like character of the restricting predicate C by representing it as the temporal inclusion predicate ‘... $\subseteq t_{fra}^m$ ’. The presuppositional status of C is captured by the further condition ‘ $t_{fra}^m = \uparrow_{loc}$ ’. Unification of \uparrow_{loc} will provide a value for t_{fra}^m which is either specified sentence internally or through contextual resolution (see Section 3.3); if \uparrow_{loc} is not unified then it remains as an anaphoric presupposition which requires resolution in context. In the existence-and-uniqueness presupposition of *der Montag* the variable t' plays the role of t^m and is therefore constrained by the condition “ $t' \subseteq \uparrow_{loc}$ ”. The presupposition also contains a further constraint on t_{fra}^m , viz. that it must include other days besides the unique Monday which the predicate *Montag* selects from it. This condition reflects the intuition that a natural use of *der Montag* is one in which the predicate *Montag* is made to do some real work in selecting the referent – the referent must be the Monday within the given interval, and not any of the other days. When *am Montag* is given a narrow scope interpretation in (28), this intuition takes the form that *oft*-quantification must be over intervals each containing a single Monday, but also other days besides; the most natural option being quantification over weeks.

The contribution of *der Montag* as we have just described it can be cast in the form shown in (29).

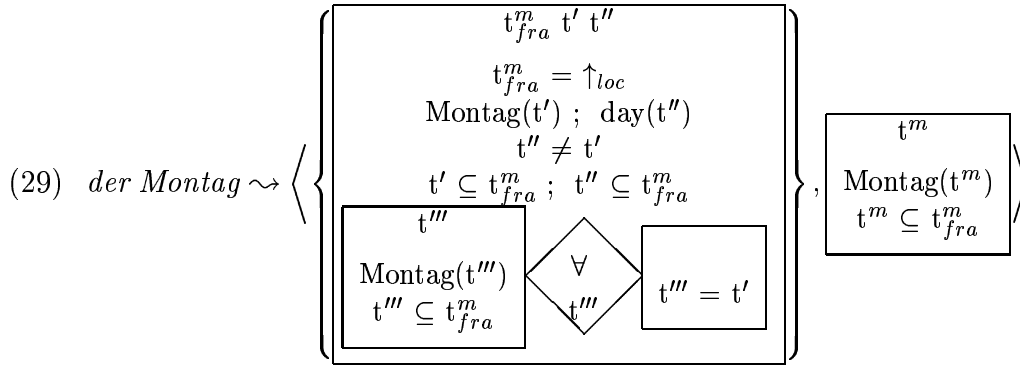

The contribution made by the PP *am Montag* relates to that of *der Montag* in the same way that in the Section 3.2 we assumed to obtain between *gestern* as adverb and *gestern* as NP. In the present instance the relation between the adverb time $\downarrow t_{loc}^{an}$ and the referent t^m of *der Montag* is given overtly by the preposition *an*, but it is once more the identity relation. So the contribution made by *am Montag* is like that of *der Montag* but with $\downarrow t_{loc}^{an}$ and the condition $t_{loc}^{an} = t^m$ added. In the UDRS (30) for (28) this contribution is displayed as the component at the bottom on the left.¹¹

¹¹Note that in this case it would have been wrong to label the component contributed by the verbal predication as l_{\perp} , as it is possible for this component to end up in the restrictor box of the duplex condition and the *Monday*-component in the nuclear scope box. Thus in general it cannot be taken as a forgone conclusion that the contribution made by the main verb of a clause is always the lowest element of the initial UDRS representing it. This presents no particular difficulties for the interpretation procedure described here. We will continue to label the verb contribution with ' l_{\perp} ' in cases where this is unproblematic.

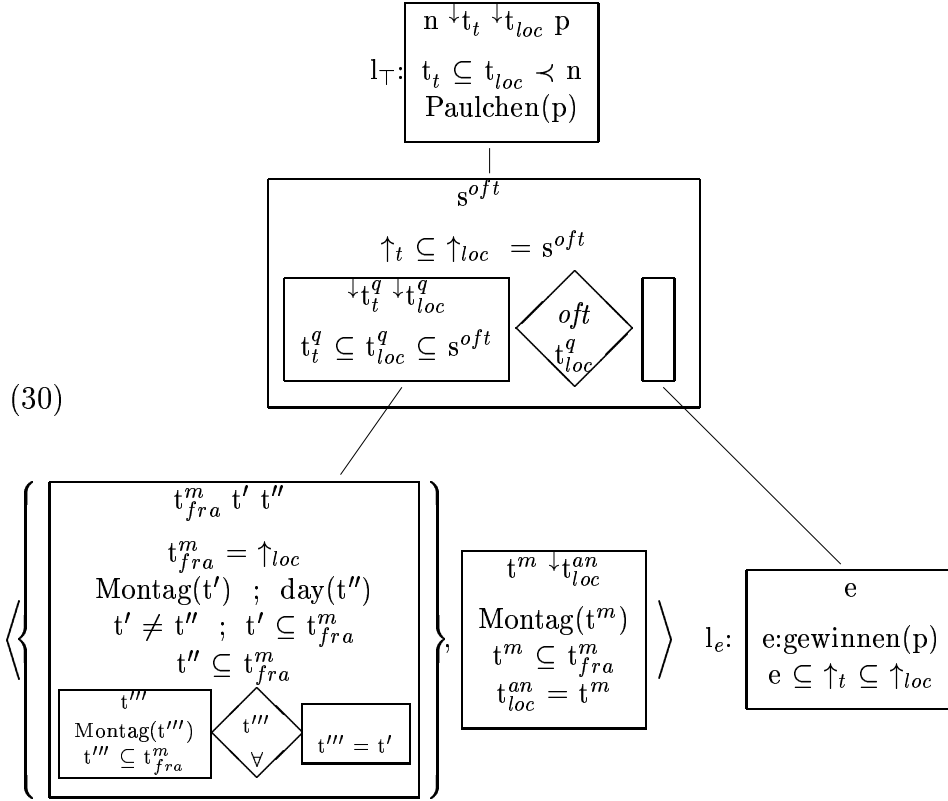

The presupposition of *am Montag* can be resolved either globally, i.e. at the top level DRS, or locally, within the restrictor of *oft*.¹² In case it is resolved globally, giving rise to an interpretation that resembles the one in (22) for (18), we again get a violation of the variety principle; variety

¹²It is worth noting how intimately this ambiguity depends on the exact form of the NP of the prepositional phrase. We see this when we compare (28) with the alternatives in (31.a) and (31.b).

- (31) a. *An einem Montag gewann Paulchen oft.*
 “On a Monday Paulchen often won.”
- b. *An diesem/jenem/dem Montag gewann Paulchen oft.*
 “On this/that/the Monday Paulchen often won.”

The ambiguity we have noted in connection with (28) is found also in (31.a) but in none of the three sentences in (31.b). The reason for this is no doubt that each of the NPs *diesem/jenem/dem Montag* only allows for a referential interpretation, according to which it refers to one particular Monday. (Remarkable in this connection is the difference between *am Montag* and *an dem Montag*.) See also [30].

is violated because once again the domain of quantification is reduced to a singleton. (This is so because (i) both $\downarrow t_{loc}^q$ and $\downarrow t_{loc}^{an}$ are unified with the ups-variable \uparrow_{loc} of l_e and thus are unified with each other; (ii) global justification of the \uparrow_{loc} of the presupposition of *der Montag* means that its \uparrow_{loc} gets resolved at the global level to a single frame within which there is, according to this presupposition, a single Monday. (i) and (ii) entail that this single Monday is the only possible value for $\downarrow t_{loc}^q$.)

Suppose on the other hand that the presupposition of *der Montag* is to be justified locally. This is most naturally achieved by unifying its \uparrow_{loc} with the quantified variable $\downarrow t_{loc}^q$. In this case the \uparrow_{loc} of l_e will be unified only with $\downarrow t_{loc}^{an}$. Furthermore the \uparrow_t of l_e must unify with the $\downarrow t_t^q$ in the restrictor of *oft*. The remaining unifications are as before. On the assumption that the constituent *am Montag* becomes part of the restrictor of *oft* l_e goes into its nuclear scope. The resulting DRS is that in (32).

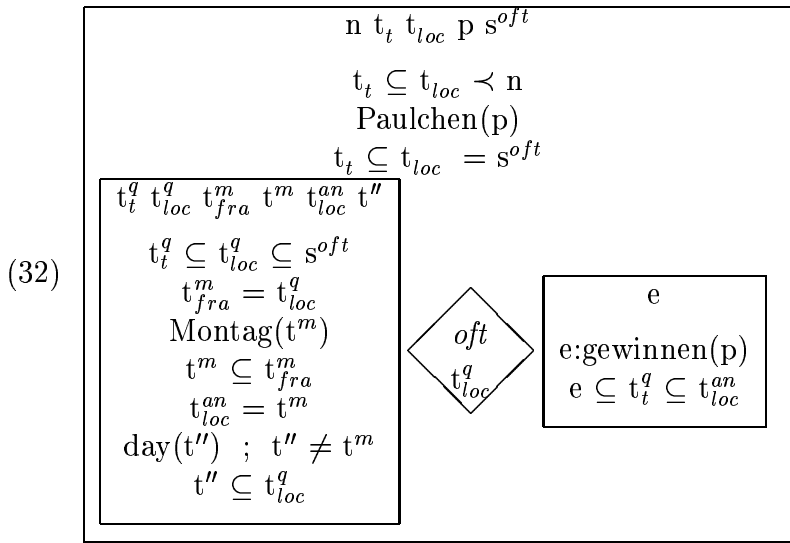

Note that in (32) the values of t_{loc}^q must include those of t^m and at least one other day. As noted above, a natural assumption regarding (32) would be that t_{loc}^q ranges over weeks. In this case t^m will select for each of the week-values for t_{loc}^q the unique Monday that this week contains.

4 The Perfect Operator

There is an extensive literature on the semantics of the so-called “perfect tenses”. A good part of it has been motivated by the intriguing properties of the present perfect in English ([38], [37], [7]). These properties are special in that they are not shared by the other “perfect forms” of English (past perfect, future perfect and infinite perfects), nor by any of the perfect tenses of most other languages which have perfects, the present perfect included. One of these other languages is German.

An analysis of the German perfect, which doesn’t display the peculiarities of the English present perfect, can, it seems, be simpler than any account of the perfect in English. This is true in particular of the analysis we adopt in this paper, and we stress that as it stands it is an analysis which wouldn’t do for English.¹³ Our analysis follows earlier accounts of the German tense and aspect system ([33], [34], [56], and [41]) in assuming that all perfect tenses have the structure $\text{TENSE}(\text{PERF}(\text{VP}))$, where PERF is an aspect operator. Within the UDRT-architecture of the present proposal it is natural to assume that PERF introduces a UDRS component which is located between l_{\top} and l_{\perp} (so that it is within the scope of tense and has scope over the contribution made by the main verb). The scope relations between the PERF component and other UDRS components are left open. This allows in particular for scope ambiguities between PERF and temporal adverbs (locating adverbs as well as quantificational adverbs).

As a first example of a scope ambiguity between PERF and a temporal adverbial consider the two sentences in (33).

- (33) a. *Am Ostermorgen war Paulchen abgereist.*
 ‘On Easter morning be_{past} Paulchen away travelled.’
 “Paulchen had departed on the morning of Easter Sunday”.
 b. *Paulchen war am Ostermorgen abgereist.*

Both (33.a) and (33.b) can be understood as saying either (i) that Paulchen’s departure occurred on the morning of Easter Sunday or (ii) that on the

¹³A uniform treatment of the perfect in English, German and Swedish is offered in [52]. Rothstein’s treatment makes an essential use of the notion of *perfective time span*, which is systematically ignored in the present paper. How to combine Rothstein’s analysis, and other uses of reference time with the theory developed here is at this point an open problem.

morning of Easter Sunday his departure had already taken place – i.e. he left before that morning.¹⁴

That this ambiguity is indeed a scope ambiguity between the perfect operator and the adverb is indicated by a comparison between (33) and (34).

- (34) a. *Gestern ist Paulchen abgereist.*
 ‘Yesterday is Paulchen departed.’
 b. *Paulchen ist gestern abgereist.*

The sentences in (34) are not ambiguous. The difference between (33) and (34) can be explained as follows. The present tense in (34.a,b) locates what it takes to be the described eventuality at the utterance time *n*. If *gestern* served to locate this same eventuality, then its denotation would have to include *n*, which it doesn’t. (It denotes the day immediately before the day of *n*.) Therefore, the eventuality located by *gestern* must be distinct from the eventuality that is located by the present tense, and moreover, the former eventuality must precede the latter one. The only way in which this requirement can be met is to take *gestern* to be within the scope of PERF. Then *gestern* will serve to locate the departure event. PERF forms out of the event description *Paulchen depart yesterday* the corresponding perfect state and this state is then located by the present tense as holding at *n*.

Thus only one of the two readings of the sentences in (33) survives in (34). The reason why we do find both readings in (33.a,b) is that here the temporal relation between the adverb *am Ostermorgen* and the past tense *war* is underspecified. The past tense refers to some time in the past of *n* and the adverb can be interpreted as referring to a past time as well. This is compatible with each of the following three possibilities: (i) the adverb time precedes the tense time, (ii) the adverb time includes the tense time, (iii) the adverb time follows the tense time. So we obtain a consistent interpretation not only when we take the adverb to have narrow scope with respect to PERF and assume that the adverb time

¹⁴There is a preference for reading (i) in the case of (33.b) and for reading (ii) in the case of (33.a), something that should have been expected given the general tendency for scope relations to align with left-to-right order. But it is a tendency only; both readings are available for both sentences; the less prominent one can be made salient by appropriate prosody or by choice of a suitable context. (Compare footnote (10)).

precedes the tense time, but also when we give the adverb wide scope and assume that adverb time and tense time overlap.¹⁵

At first sight it may look as if this explanation runs afoul of sentences like those in (35).

- (35) a. *Heute ist Paulchen abgereist.*
 “Today Paulchen has departed.”
- b. *Gestern war Paulchen abgereist.*
 “Yesterday Paulchen had departed.”

(35.a,b) may seem unambiguous, like the sentences in (34) and unlike those in (33). If this were indeed the case, then our scope-based account of the possible readings for (33) and (34) would be in trouble. Consider for instance (35.a). Here we cannot exclude the second reading of the sentences in (33) in the way we did for the sentences in (34). For (34) our argument was based on the fact that the denotation of *gestern* does not include the utterance time. But the denotation of the adverb of (35.a), *heute*, does include the utterance time. Similarly, as regards (35.b), nothing prevents inclusion of the (past) tense time in the denotation of *gestern*.

We believe, however, that the sentences in (35) are ambiguous after all, first appearances notwithstanding. For (35.a) the “missing” reading is easier to get in a context such as (36.a). And the same applies to (35.b). Its “missing” reading becomes prominent in the analogous context (36.b).

¹⁵The third option – adverb time follows tense time – does not yield a possible interpretation. Note that whether we take the adverb to have (a) wide or (b) narrow scope wrt. PERF, the interpretation would have to be a prospective one: from the perspective of the tense time either (a) the result state or (b) the event itself would lie in the future. The possibilities for such prospective interpretations of past tenses are very limited. An example is the much discussed *Morgen war Weihnachten*, (see [20]) which can be used to express that from the past vantage point of some protagonist the following day would be Christmas. Although we will have something to say about the prospective uses of the present tense in Section 5, we have decided not to consider in this paper the corresponding uses of past tenses. This decision is reflected in the simplified entry for the German past tense which was given in (10) and (25). This entry allows for an interpretation where the tense time either includes the event of Paulchens departure or is included in the state resulting from his departure, but not for a ‘prospective’ state of his going to depart.

- (36) a. *Vorgestern war er noch da. Aber heute ist Paulchen abgereist.*
 ‘before-yesterday was he still there. But today is Paulchen away-travelled.’
- b. *Vor drei Tagen war er noch da. Aber gestern war Paulchen abgereist.*
 ‘Ago three days was he still there. But yesterday was Paulchen away-travelled.’

While the sentence in (35) are thus no counterexamples to our scope based analysis of these in (33) and (34), the analysis does not explain why the second reading is so much harder to get in (35) than in (33). To that question this paper provides no answer.

Related to this last question is the contrast between the sentences in (35) and those in (37).

- (37) a. *Heute ist Paulchen verreist.*
 “Today Paulchen has departed.”
- b. *Gestern war Paulchen verreist.*
 “Yesterday Paulchen had departed.”

Like those in (35) these sentences are ambiguous. But they differ from (35) in that the second reading is easy to get – perhaps even easier than in the case of (33). This contrast between (35) and (37) must be due to distinct properties of the two verbs *abreisen* and *verreisen*, since it is only in their verbs that the sentences differ.

The relevant distinction between *verreisen* and *abreisen*, it has been observed (see [35]), is that *verreisen* has what has been called a *target state* in [44], whereas *abreisen* does not. A target state of a verb V is a state which entails that an eventuality of the kind described by V occurred before it, but it is more than that. It is a state which is caused by such an eventuality, but which can subsequently disappear again, either because it has run its course or peters out. For instance, a target state of *verreisen* is one where the subject is away from home as a consequence of an earlier *verreisen*-event (an event consisting in the subject taking off from his or her domicile). When the subject returns, the target state is thereby terminated, and at that point it is misleading to say, *Er/Sie ist verreist*. (However, the target state interpretations of such sentences

can be overwritten. *Er ist verreist, aber er ist jetzt wieder nach Hause gekommen.* – Engl.: *He has left, but now he has come back home.* – is perfectly acceptable.)

The target state of a verb is described by its past participle. When the participle is used for this purpose, it functions much like an adjective. This endows a sentence like (37.a) with an interpretation which resembles those of present time sentences like *Heute ist Paulchen krank.*, which also assert that an adjectivally described state holds during the including denotation of their temporal adverb. There of course remains a difference between such present tense copula sentences and sentences involving past participles like (37.a): the latter describe states which entail the occurrence of some event whose result state they are, while the former do not. But this event is much less prominent than it is in the case of perfects involving non-target state verbs, and this is reflected by the fact that for target-state verbs it is easier to obtain readings in which the temporal adverb is understood as locating the result state and not the eventuality whose result state it is.

Scope ambiguities arise also between PERF and quantificational adverbs. For instance (38)

- (38) *Paulchen hat oft getrunken.*
 ‘Paulchen has often drunk.’

is ambiguous between a reading which says that before the utterance time there were many occasions when Paulchen drank – something that might be said, for instance, in summing up Paulchen’s sojourn in this vale of tears after he has passed away – and one according to which there are many occasions on which he has drunk and on which he still shows the effects of having done so (i.e. is still inebriated). According to our analysis, which predicts such scope ambiguities between PERF and quantification adverbs just as it predicts scope ambiguities between PERF and adverbs like *gestern* and *heute*, this is as it should be. But here too our theory is not able to explain why some readings are much harder to get than others.

4.1 Ups and downs in PERF

We now proceed to our formal treatment of the German perfect. German perfects are composed of an auxiliary and a past participle (which we

assume is marked in syntactic structure as “PERF = +”, or, more compactly, as “+PERF”). The auxiliary carries the information contributed by tense. The feature “PERF = +” of the participle contributes a UDRS component (given in (39)) which introduces a discourse referent s^{res} representing the “formal” result state denoted by the participle. s^{res} is assumed to be the result of an eventuality ev of the kind described by the verb. (The result relation between s^{res} and ev is expressed by the DRS condition “ $res(s^{res}, ev)$ ”). Like other eventualities s^{res} is temporally located by ups-variables \uparrow_t and \uparrow_{loc} . The temporal relation between s^{res} and ev is that of abutment: $ev \supseteq s^{res}$. (This is a general entailment of the condition that s^{res} is the result state of ev – i.e. “ $res(s^{res}, ev)$ ” logically entails “ $ev \supseteq s^{res}$ ”). The downs-variables $\downarrow_{t_t}^{ev}$ and $\downarrow_{t_{loc}}^{ev}$ serve to secure the importation into the representation component provided by (39) of the eventuality ev of which s^{res} is the result state; the symbol ‘ \uparrow_{ev} ’ acts as a place holder for this eventuality. Importation of ev – i.e. assigning it to the positions held by \uparrow_{ev} – results when the downs-variables $\downarrow_{t_t}^{ev}$ and $\downarrow_{t_{loc}}^{ev}$ unify with ups-variables from a UDRS component containing a distinguished eventuality discourse referent ev . (A UDRS component which provides matching ups-variables \uparrow_t and \uparrow_{loc} for the downs-variables $\downarrow_{t_t}^{ev}$ and $\downarrow_{t_{loc}}^{ev}$ will always have a unique discourse referent ev occurring in one of the conditions ‘ $ev \subseteq \uparrow_t \subseteq \uparrow_{loc}$ ’ or ‘ $\uparrow_t \subseteq \uparrow_{loc} \subseteq ev$ ’.) The symbol \uparrow_{ev} must be distinguished from the ups-variables considered so far. \uparrow_{ev} just serves the purpose to identify the positions into which the distinguished discourse referent ev from the ups-variable component must be inserted. (It doesn’t unify in the way of our ups-variables since there are no matching downs-variables for it.)

The insertions of ev for \uparrow_{ev} are part of a more complex operation in which the ups- and downs-variables are unified and the UDRS-components containing these variables are merged.¹⁶ There is no difficulty in describing this operation formally: It consists of (i) unifying the ups- and downs-variables of the two components, (ii) inserting the distinguished eventuality discourse referent from the ups-variable component into the

¹⁶We have used the symbol \uparrow_{ev} as a graphic reminder that the ups-variable component not only must stand in the relation \leq to the component provided by (39) in the UDRS resulting from the unification, but that the relation \leq also holds in the opposite direction, which means that the two components are merged. For details see Section 7.

positions occupied by \uparrow_{ev} in the downs-variable component, and (iii) merging the two components which result from these operations into a single DRS (in the usual sense of DRS-merge, i.e. forming the union of the DRS-universes and of their condition sets). And this operation is required if and only if the component with the downs-variables contains the symbol \uparrow_{ev} .¹⁷ It should be stressed, however, that this is an operation which *is* different from those we have considered up to this point. As things stand we must admit this as a simple primitive operation – one of those which are involved in the interpretation algorithm presented here. In view of the apparent complexity of the operations this may be perceived as a point where the present proposal ought to be improved. This task of simplifying the basic formal operations of the theory can be meaningfully addressed only within the larger context in which the present proposal is integrated into an interpretation algorithm which also deals explicitly with a significant range of non-temporal aspects of interpretation. And that is a task we cannot undertake here.

$$(39) \text{ PERF} = + \quad \rightsquigarrow \quad \boxed{\begin{array}{c} s^{res} \downarrow_t^{ev} \downarrow_{loc}^{ev} \\ \uparrow_t \subseteq \uparrow_{loc} \subseteq s^{res} \\ \text{res}(s^{res}, \uparrow_{ev}) \\ \uparrow_{ev} \supset s^{res} \end{array}}$$

For an example consider the sentence in (40).

¹⁷The need for some form of binding of eventuality variables is something which PERF shares with other aspect operators. (For other aspectual operators see Sections 5 and 6.) In more traditional “formal semantics”, such operators always require operands which are of the type of a property of eventualities, and so could be cast in the form “ $\lambda EV.ASP(EV)$ ” where EV is a variable of the type of a property of eventualities (or of an “eventuality type” as we ourselves prefer to call it) and ASP denotes some function from eventuality types to eventuality types. The argument of ASP will then typically take the form “ $\lambda ev'.OPD(ev')$ ”, where ev' is the designated eventuality variable of what in our set-up is the relevant UDRS-component (in the case under discussion as many others this will be the component l_{\perp}). PERF differs from most other aspect operators in that it is “veridical”: applying it to its argument has the effect of instantiating the λ -bound eventuality variable of the argument by a variable that is existentially bound with *de facto* wide scope in the result returned by the operator. As familiar from Montague Grammar, such “extensional” operators can be represented in the form “ $\lambda EV.(\exists ev')(ASP'(ev') \wedge EV(ev'))$ ”, where ev' corresponds to our \uparrow_{ev} . In our current proposal all such aspect operators require applications of the complex ‘unify-insert-merge’ operation described above.

- (40) *Paulchen ist gestern verreist.*
 “Paulchen has yesterday gone on a trip.”

(41) gives a syntactic analysis for this sentence in which the V-node dominates the complex consisting of participle and auxiliary (represented by its trace t_2 after movement to the V2-position). The participle has been decomposed into the lexical verb and the PERF-operator, which is morphologically realised as *-ed* and whose semantics is indicated by the feature value +PERF.

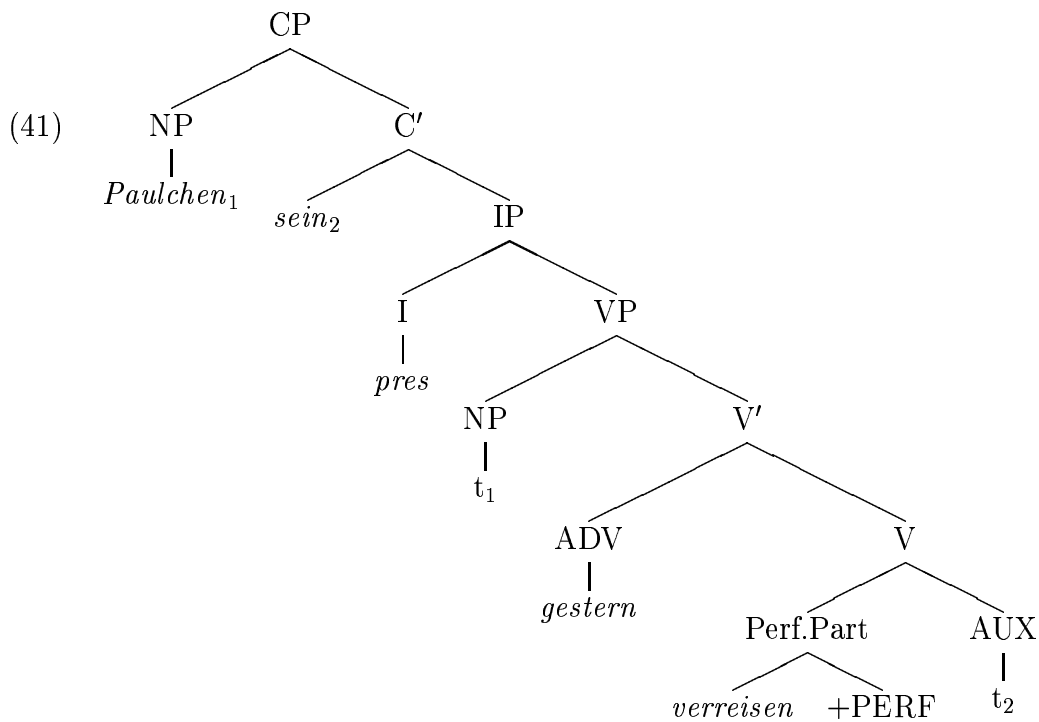

Insertion of the semantic representations of the different lexical items of (41) leads to the decorated tree in (42).

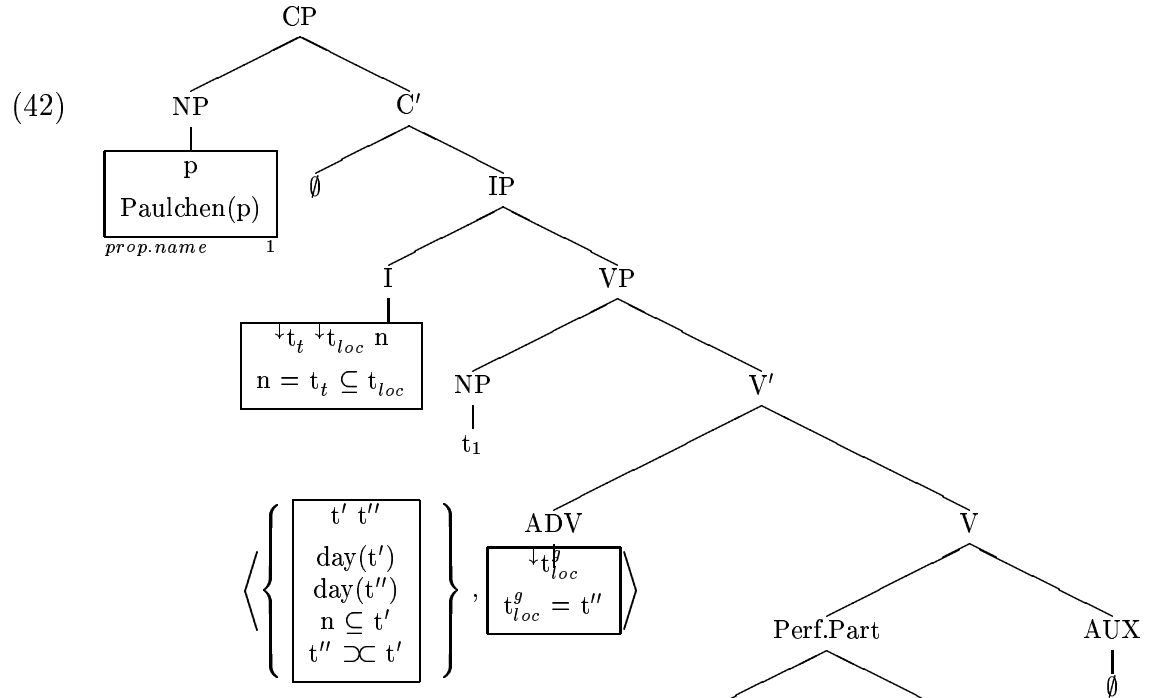

(42) gives rise to the UDRS in (43).

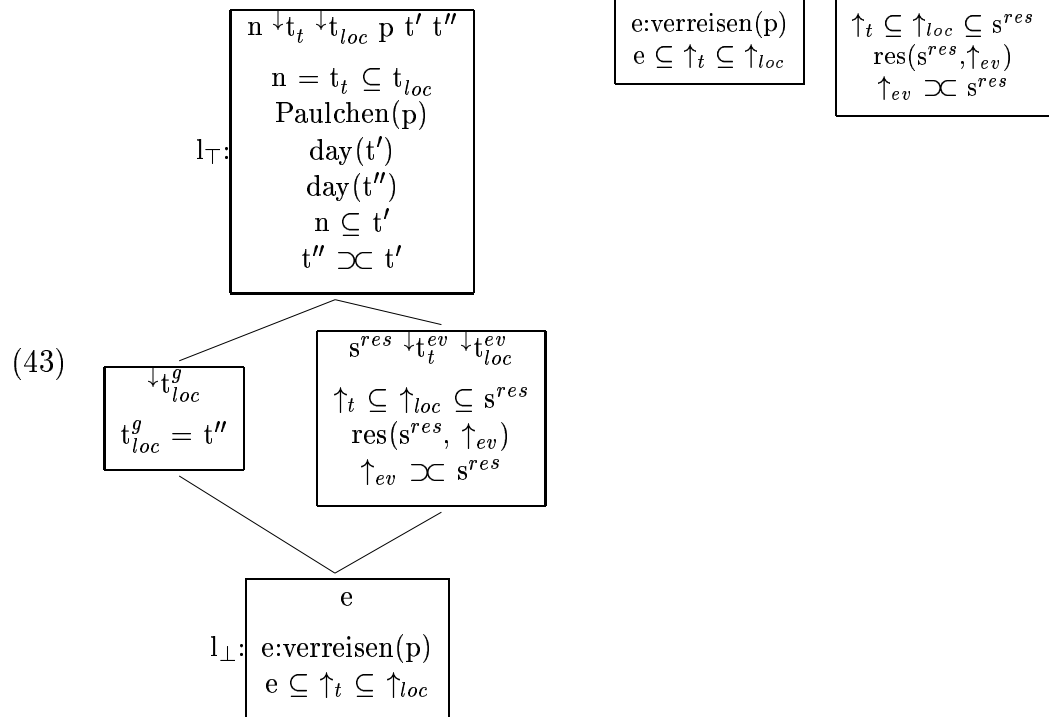

The algorithm now converts (43) into a DRS. Again proceeding bottom up, it first tries to find a binder for the ups-variables in l_{\perp} . It is easily seen that the only option for \uparrow_t is unification with the variable $\downarrow t_t^{ev}$ from the PERF component. (Otherwise the \uparrow_t from PERF would remain without unification mate.) This means that the \uparrow_{loc} of l_{\perp} also has to unify with the downs-loc variable from PERF, i.e. with $\downarrow t_{loc}^{ev}$. But loc-unification need not be one-to-one. There still remains a choice: either the \uparrow_{loc} of l_{\perp} is also unified with the variable $\downarrow t_{loc}^g$ from the *gestern* component, or $\downarrow t_{loc}^g$ is left to unify with the \uparrow_{loc} from PERF. All other unifications are determined by the structure of (43). So we get two possible solutions, viz. the DRSs in (44).

	$ \begin{array}{l} n \ t_t \ t_{loc} \ p \ t_{loc}^g \ s^{res} \ t_t^{ev} \ t_{loc}^{ev} \ e \ t' \ t'' \\ n = t_t \subseteq t_{loc} \\ \text{Paulchen}(p) \\ \text{day}(t') \ ; \ \text{day}(t'') \\ n \subseteq t' \ ; \ t'' \supseteq t' \\ t_{loc}^g = t'' \\ t_t \subseteq t_{loc}^g \subseteq s^{res} \\ \text{res}(s^{res}, e) \\ e \supseteq s^{res} \\ e:\text{verreisen}(p) \\ e \subseteq t_t^{ev} \subseteq t_{loc}^{ev} \end{array} $		$ \begin{array}{l} n \ t_t \ t_{loc} \ p \ s^{res} \ t_t^{ev} \ t_{loc}^{ev} \ t_{loc}^g \ e \ t' \ t'' \\ n = t_t \subseteq t_{loc} \\ \text{Paulchen}(p) \\ \text{day}(t') \ ; \ \text{day}(t'') \\ n \subseteq t' \ ; \ t'' \supseteq t' \\ t_t \subseteq t_{loc} \subseteq s^{res} \\ \text{res}(s^{res}, e) \\ e \supseteq s^{res} \\ t_{loc}^g = t'' \\ e:\text{verreisen}(p) \\ e \subseteq t_t^{ev} \subseteq t_{loc}^g \\ t_{loc}^{ev} = t_{loc}^g \end{array} $
--	--	--	---

Note that only the right hand side in (44) is consistent. This DRS asserts that the departure took place yesterday. The left hand side DRS is inconsistent because the conditions ' $t_t \subseteq t_{loc}^g$ ' and ' $t_t = n$ ' force inclusion of the speech time within the day before it, which is obviously impossible.

As we saw in the introduction to this section, the matter is different when we replace *gestern* by *heute*, for then the contradiction of the left hand side representation (44) disappears. So let us consider the next sentence (45) and the representations that result from (44) by replacing the contribution of *gestern* by its obvious analogue for *heute*.¹⁸

¹⁸A final form of the entry for *heute* will be given in Section 5.

- (45) *Paulchen ist heute verreist.*
 ‘Paulchen is today away-travelled.’

According to the scoping on the right of (44) (45) says that the event of departing lies in the past part of the day of the utterance; and the scoping on the left gives an interpretation according to which the utterance day is characterized by a state that results from the fact that there was a departure at some earlier time – that is, at some time *before* that day.

We already noted in the introduction to this section that the ambiguity of (40) is at best marginally present when *verreist* is replaced by *abgereist*. The likely reason for this distinction, we observed, is that *verreisen* gives rise to a “target” state – a result state which consists of more than the mere fact of a preceding *verreisen* event – whereas *abreisen* does not. The target state of *verreist* requires that the agent hasn’t yet returned to his place of departure (which in the case of *verreisen* must be the place that counts as home). In (46) the existence of such target states is expressed in the form of a meaning postulate.

$$(46) \quad \boxed{\begin{array}{c} \mathbf{x}^{subj} \ e \\ e:\text{verreisen}(\mathbf{x}^{subj}) \end{array}} \rightarrow \boxed{\begin{array}{c} \mathbf{s}^{res} \ h \\ \mathbf{x}^{subj}\text{'s home}(h) \\ \mathbf{s}^{res}:\neg\text{AT}(h,\mathbf{x}^{subj}) \\ e \supset \mathbf{s}^{res} \end{array}}$$

This postulate presents the occurrence of a target state (represented as “ \mathbf{s}^{res} ”, with “**res**” in bold face as opposed to general result states which we denote as “ s^{res} ”) as a consequence of an event of type *verreisen* having taken place. In order that this postulate can account for the difference we have noted between (40) and its *heute*-counterpart (45) we need a further constraint – one to the effect that temporal locating adverbs are normally understood as locating “genuine” eventualities, and that target states are among these, but result states in general are not.¹⁹

¹⁹Result states of verbs which don’t have target states (in the sense that they do not have meaning postulates of the type of (46) associated with them) can occasionally be located by temporal adverbs too, viz. in contexts where sufficiently strong factors are present to coerce such an interpretation. Coercion, however, is a topic beyond the scope of this paper. It appears that those German verbs which give rise to target states all select for *sein* (*be*) as opposed to *haben* (*have*) as perfect-auxiliary.

4.2 Complex UDRS-conditions and PERF

So far we have looked at the interaction between the perfect operator, tense and temporal locating adverbs. Matters become more complicated when quantification enters the game as well. Sentences with perfect tense morphology and adverbial quantifiers also lead to initial UDRSs in which PERF and adverb contribute distinct components, of which we assume that they are not yet ordered with respect to each other. For example, consider the sentence in (47) with initial representation in (48).

- (47) *Paulchen ist gestern oft eingeschlafen.*
 “Paulchen has often fallen asleep yesterday.”

(Although as we have seen, not all verbs with *sein*-perfects have target states). It also seems that English verbs never give rise to target states with the same grammatical properties that distinguish the German target states spoken of here. For instance, as far as we can tell, the sentences *John has departed today.* and *John has gone on a trip today.* only have the reading corresponding to the right hand side of (44), but not that corresponding to the DRS on the left. It is a tempting speculation that this property of the English sentences is related to the fact that English perfects are without exception formed with the auxiliary *have*. In fact, it is our impression that in English the stricture against interpretations in the sense of the right hand side (44) is even stronger than it is for non-target state verbs in German, including German *haben*-verbs. If it is indeed true that for English the restriction is absolute, an account of the English perfect will probably have to be fundamentally different from the one offered here for German perfects, in which scope relations between the perfect operator, locating adverbs and other representation components do almost all the work.

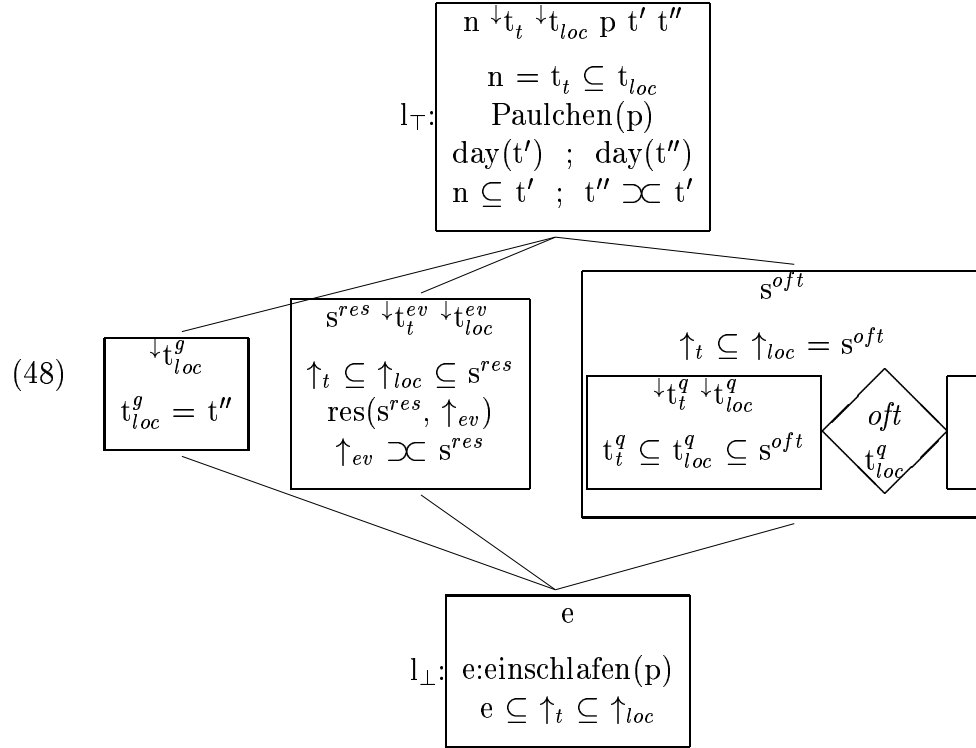

Resolution of the scope relation between PERF and the quantifier component can go either way. If we assume that in (48) PERF takes scope over the quantifier component and that *gestern* is interpreted as the duration of s^{oft} (i.e. as the temporal quantification frame for *oft*) we obtain the representation in (49).

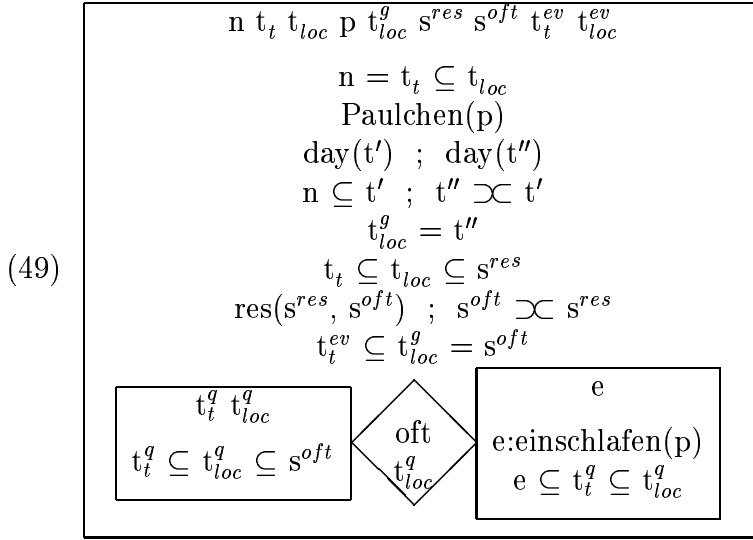

(49) assigns (47) a reading which it evidently has. But (49) represents only one of a total of 6 different scope orderings between *gestern*, *oft* and PERF all of which might be thought to be possible in principle. Not all of these orderings assign (47) a reading that speakers admit, however. We devote the remainder of this section to the further readings (47) and similar sentences do have and why it is just those that are acceptable. We have seen that the initial UDRS (48) for (47) has three components which are ordered only with respect to l_{\top} and l_{\perp} , but not vis-a-vis each other. Let us refer to these three components as “PERF”, “QUA” (for the quantifier component) and “ADV” (for the component contributed by the locating adverb). The UDRS in (48) is in principle ambiguous between the six different scope orderings of these three elements which are listed schematically in (50).

- (50)
- a. PERF ADV QUA
 - b. PERF QUA ADV
 - c. ADV PERF QUA
 - d. ADV QUA PERF
 - e. QUA PERF ADV
 - f. QUA ADV PERF

The interpretation represented in (49) reflects the scope option (50.a). Of the five other options, (50.c) and (50.d) turn out to be impossible

for the sentence (47) because the reference of *gestern* is incompatible with the constraints imposed by the present tense. (This, however, is an accidental feature of the particular sentences in question. We return to these two scope options below.)

Three options remain, (50.b), (50.e) and (50.f). Given our unification assumptions (50.b) fails because of a violation of variety: $\downarrow t_{loc}^g$ and $\downarrow t_{loc}^q$ both unify with the \uparrow_{loc} of l_{\perp} and are thus identified. This identification reduces the range of possible values for the quantificationally bound variable $\downarrow t_{loc}^q$ to a singleton. (50.f) is filtered out for the same reason. This time both $\downarrow t_{loc}^g$ and $\downarrow t_{loc}^q$ unify with \uparrow_{loc} of the PERF component. (50.e), on the other hand, does not violate quantificational variety, since $\downarrow t_{loc}^g$ unifies with the \uparrow_{loc} of the event and $\downarrow t_{loc}^q$ with the \uparrow_{loc} of its result state. Thus $\downarrow t_{loc}^g$ is not identified with the variable $\downarrow t_{loc}^q$ bound by the quantifier.

To explain the reason for the oddity of (50.e) let us first consider the pluperfect sentence *Paulchen war um 6 Uhr eingeschlafen*. (Engl.: *Paulchen had fallen asleep at 6 o'clock*.) This sentence is ambiguous between (i) a reading according to which 6 o'clock is taken to be the reference time wrt. which the pluperfect is evaluated, i.e. a reading according to which the event of falling asleep happened before 6 o'clock, and (ii) a reading saying that the event happened at 6 o'clock and the reference time is after 6 o'clock. A representation of the first reading can be obtained by letting the perfect take narrow scope wrt. the adverbial, which then locates the result state at 6 o'clock. In reading (ii) the adverbial first locates the event at 6 o'clock and then the PERF operator is applied to the event characterisation thus obtained.

Now consider the unacceptable *Um 7 Uhr war Paul um 6 Uhr eingeschlafen*. (Engl.: *At 7 o'clock Paulchen had fallen asleep at 6 o'clock*.) Without further constraints our representation algorithm would allow taking *at 7 o'clock* as reference time for the location of the result state while interpreting the rest of the sentence as in (ii). The impossibility of past perfect sentences like this one is, we believe, an indication that one cannot use within the same clause two locating adverbs denoting disjoint times in such a way that one of them locates the event and the other its result state. In interpreting a clause that involves a perfect one has to make a choice between two options: either one takes the event as the 'principal eventuality described by the clause', in which case a temporal locating adverbial in the clause can only be understood as locating it; al-

ternatively, the main eventuality is taken to be the result state, but then a locating adverb can only be understood as locating this state. But one can't have it both ways, and so there is no room for two locating adverbials in the same perfect clause, each with its own localisation task. As it stands, this principle doesn't tell us anything about sentences like (47); but it does do that if we make the additional assumption that from the present point of view there is no real difference between quantificational adverbs like *oft* and locating adverbs like *gestern*, *on Monday*, etc. which refer to particular reference times. Just as the location times supplied by locating adverbs only serve to locate the principal eventuality of the clause, this is equally true of the location times introduced by quantifying temporal adverbs. The implication of this assumption is that in the interpretation of (51), where PERF is in the immediate scope of the quantifier *oft*, and the quantificationally bound t_{loc}^q is construed as locating the result state, there is no room for an additional locating adverb that locates the events of which these states are the result states. For by construing the quantification as pertaining to the (location times of the) result states, these result states are made *ipso facto* into the principal eventualities of the clause. The events are thereby excluded from this status and their localisation by means of an additional locating adverb has become impossible.²⁰

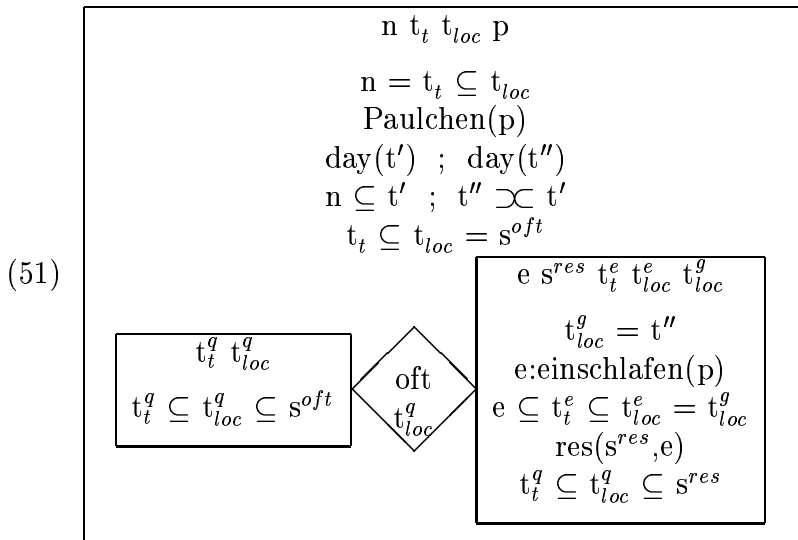

²⁰Note that this 'double location constraint' also prohibits (50.b). This configuration is thus eliminated for two distinct reasons, variety and double location.

One consequence of these assumptions about the role of locating and quantifying adverbs is that a quantifying adverb cannot be assumed to have scope over both PERF and a locating adverb, which refers to one, fixed time stretch. For either the adverb is then construed as further specifying the location time of the result state, in which case we have a violation of variety, or the adverb is construed as locating the event, in which case there is a conflict with the assumptions just made.

To sum up the argument so far, there is only one of the six scope possibilities listed in (50) which leads to a viable interpretation for (47), viz. (50.a); and as far as we can see, this is in agreement with speaker's intuitions about (47). However, in connection with (47) two of the six possibilities in (50) – (50.c) and (50.d) – could be eliminated because of the conflict between *gestern* and present tense. But as we noted, this rests on an accidental feature of this particular example. In (52) this convenient source of conflict has been eliminated.

- (52) *Paulchen war gestern oft eingeschlafen.*
 'Paulchen had often fallen asleep yesterday.'

For (52) it seems that both the scope orderings (50.c) and (50.d) yield possible readings. The reading induced by (50.c) can be paraphrased as: Yesterday was a day when there were many times at which Paulchen was in the state of having fallen asleep (i.e. in the state of having just dozed off.) The reading induced by (50.d) is not so easy to get, but this is for contingent reasons. A better example for this reading is the sentence: *Damals hatte er oft Erfolg gehabt. (Aber heute würde ich ihm keine zweite Chance mehr geben.)* (Engl.: *At that time he had often been successful. (But today I wouldn't give him another chance.)*) Here the time referred to by *damals* is naturally interpreted as one at which the state holds that resulted from there having been many different previous occasions where the subject succeeded (with whatever it was he undertook). In the case of (52) this interpretation is odd insofar as it seems somehow difficult to conceive of a state which is the result of many preceding falling asleep events, especially as the period within which there were many falling asleep events remains unspecified. In addition to these interpretations for (52) we believe that (52) also has a reading corresponding to (50.a) though admittedly such a reading is not easy to get. (It would require

reference time preceding the speech time but still belonging to the same day, at which the state obtains which results from Paulchen often falling asleep on the preceding day. Such an interpretation is natural in a context where one recalls, some time in the afternoon of a certain day *d*, a thought or conversation which took place that morning. At that earlier time someone did say (or could have said) *Paulchen ist gestern oft eingeschlafen.*) It follows from our consideration in connection with (47) that the remaining scope possibilities listed in (50) are again ruled out, so that we end up with three readings for (52), corresponding to (50.a), (50.c) and (50.d).

So far so good. But (47) and (52) are only two from a much larger range of sentences in which the possible interpretation of the perfect with locating and quantifying adverbials raise similar questions. And there seems no clear guarantee that other sentences will present difficulties for the present account that are not so easily overcome. In the light of this the reader may wonder if our analysis of the perfect tenses as composed of the ordinary tense and the operator PERF doesn't import a set of problems, of which we don't know as yet that they are all solvable, and which might have been avoided in the first place. One alternative analysis that comes to mind in this connection is that according to which the perfect is a morphological variant of the simple past. This claim has been made in particular in relation to the use of the perfect in Southern parts of Germany, where it has largely replaced the simple past tense morphology. It should be pointed out, however, that this can hardly provide a solution. In the first place it could help, if at all, only in connection with sentences in the present perfect such as (47), but not with past perfect sentences like (52). Moreover, even the present perfect isn't always exchangeable with the simple past (for those speakers for whom simple past morphology is unproblematic²¹). So, in order to get

²¹The most salient examples showing that simple past morphology and present perfect morphology are not always interchangeable are those involving indirect discourse. *Paulchen sagte, dass er krank war.* (Engl.: *Paulchen said that he was ill.*) has as one of its interpretations – and arguably this is the more salient one – that Paulchen asserted that he was ill at the time when he made his assertion. (In other words the corresponding oratio recta would have been “*Ich bin krank.*” (“*I am ill.*”). The sentence *Paulchen sagte, dass er krank gewesen ist.* (Engl.: *Paulchen said that he has been ill.*) does not have this reading. It is only coherent in a situation where the current utterance time and the earlier time at which Paulchen made the statement

any mileage out of the alternative approach for the problem at issue we would (a) have to have a way of telling which occurrences of the present perfect forms may be analysed as simple pasts and (b) have reason to suppose that the scope problem can be solved, or solved more easily, for those sentences whose present perfects cannot be treated as simple pasts. We do not know of any solution of (a), and in the absence of that it is impossible to do more than stipulate about (b). So, as things stand, reduction of perfects to simple pasts does not promise to be of much help.

Moreover, reflections on the possible readings of sentences which on our proposal do involve the scope options we have discussed do, it seems to us, reveal that these options are real. So this is a problem with which our theory which covers both temporal quantification and the perfect will have to cope.²²

that is being attributed to him both belong to the same “extended now”; and in that case the state of illness of which Paulchen is said to have spoken must be understood as lying in the past of this extended-now interval. (See [42] on the so-called “double access” interpretations of “present under past” sentences.) Outside the domain of indirect discourse, straightforward examples showing the non-interchangeability of perfect and simple past are not so easy to find. But even the examples just mentioned demonstrate that perfect and simple past cannot be regarded simply as alternative morphological realisations of the same semantic construct. See [17] and [33].

²²As a matter of fact the majority of current theories of the perfect, for German and many other languages, assume some form of compositional analysis according to which perfect tense forms result from a combination of the perfect operator and various tenses. See in particular [1].

Ups and Downs in the Theory of Temporal Reference

Uwe Reyle, Antje Rossdeutscher, Hans Kamp

Part II. Ups-Downs Unifications and Lexical Ambiguity

5 German Present Tense

In Sections 2 and 3 of Part I we only considered one interpretation for the present tense, according to which it locates the described eventuality as overlapping with the utterance time n . But as we showed in Section 1.2, this is a simplification which fails to do justice to the true range of possible meanings of the German Präsens. Our task in the present section is to give a more faithful account of the semantic range of the Präsens, and of the ways in which the different possibilities which it covers interact with other components of present tense sentences.

For a proper understanding of these interactions it is important to draw attention to a special constraint which applies – not only in German, but, it seems, in natural language generally – to statements which situate the described eventuality at the utterance time. We have been proceeding on the assumption that the temporal relation between an eventuality ev and its eventuality time t_t depends on the nature of ev – if ev is an event e , then the relation is inclusion of e in t_t , “ $e \subseteq t_t$ ”; if it is a state s , then the inclusion is reversed: “ $t_t \subseteq s$ ”. These conditions hold irrespective of where t_t is situated with respect to n . But they take on a special significance in those cases where t_t coincides with n , as required by the present tense when it is used in the sense given by the entry in (10) (or, equivalently as far as the present point is concerned, by the revised entry in (25)). The reason for this is a further principle, which prohibits

the relation “ $ev \subseteq n$ ” except when the present tense is used in one of a number of special ways. In other words, unmarked uses of the present tense in which it is interpreted according to its entry in (10) or (25) are possible only when the sentence describes a state, but not when it describes an event.

Prominent among the ‘marked’ uses of the present tense to which this prohibition does not apply are those known in the literature as the *reportive present* and the *historical present*. (But there are also some other exceptions to the prohibition which arguably do not fall within either of these two categories.) The reportive present is a use of present tense morphology in which each separate (sentential) utterance event is interpreted as providing the deictic anchoring point for the tense of the particular sentence that is just being uttered: the event described in the uttered sentence is taken as simultaneous with the event of uttering that very sentence. The historical use of the present tense is a mode of narration of past episodes in which each sentence is to be seen as involving a fictitious “quasi-utterance time” which coincides with the past eventuality that the sentence speaks of. In both these uses, it has often been noted, the special connection between described event and utterance event that the present tense establishes tends to produce in the interpreter a sense of direct involvement with the subject matter of the discourse, an involvement which would have been absent or less compelling had the speaker/author employed some other mode of discourse.

That the condition “ $ev \subseteq n$ ” is allowed only for such special uses of the present tense is a well-known fact (see [54], [31] or [28]). But why this should be so is another matter. Our conjecture is as follows. In those kinds of discourse where the conditions for the marked uses of the present tense do not apply, the utterance time is on the one hand conceived of as a point. At the same time, however, all points within the duration T_d of the discourse are thought of as equally good candidates for playing the role of utterance time. This second conception reflects an understanding of the discourse as temporally static: nothing that is of importance to what it talks about changes while it is in progress. It should not matter, therefore, for assessing the truth conditions of any proposition expressed in the course of the discourse, with respect to which of the points within T_d the sentence expressing that proposition is evaluated – i.e. which of these points is taken as its utterance time n . It should be clear that

these assumptions are incompatible with the condition “ $ev \subseteq n$ ”. For let t_1 and t_2 be two distinct points within T_d . Then the conditions we get by identifying n with t_1 and t_2 , respectively, viz. “ $ev \subseteq t_1$ ” and “ $ev \subseteq t_2$ ”, will normally not both be satisfied. So a sentence expressing a proposition whose representation includes “ $ev \subseteq n$ ” will be inadmissible as part of a discourse of this type.²³

What has just been said would seem to imply that present tense sentences which describe events are inadmissible unless their tenses are given one of the marked interpretations we have discussed. But this is not so, for there are yet other ways of interpreting present tense morphology, which do not conform to the entries in (10) and (25). The first of these, which seems available in a wide variety of languages, is the family of habitual and generic interpretations. According to such interpretations events of the kind described by the sentence happen regularly or typically whenever certain conditions are fulfilled, usually over some period of time which is either implied or given explicitly (e.g. by an adverb in the sentence itself, in much the same way as *gestern* is understood as determining the interval delimiting the quantification expressed by *oft* in (18) of Section 3.)

In addition, German has (as opposed to, for example, English) two further options. First, present tense event sentences often allow for a progressive reading. For instance, *Paul schreibt einen Brief.* can be interpreted to mean the same thing as the sentence *Paul is writing a letter* in English. Secondly, as we noted in Section 1 German is one of the languages in which the present tense allows for prospective interpretations (see (3)).

This summarises the options that are available when the German present tense is used in an ‘unmarked’ way. It is on the unmarked use and the interpretational options that it allows for that we will concentrate in the next section. The remainder of this section will be devoted to two points. First we will say something about ‘marked’ uses of the present tense and then, taking our clues from what we will have learned from

²³Note that it is a constraint on discourse of the kind described here that only such eventualities can be described which either (i) lie entirely in the past of T_d , (ii) lie entirely in the future of it, or (iii) include T_d , in which last case they must be conceived as states. These three possibilities are mutually exclusive but they are not jointly exhaustive.

our exploration of the German present, about the difference between ambiguity and underspecification.

The ‘marked’ uses of present tense sentences, in particular the reportive present and the historical present, raise issues that are quite different from those that arise with the ‘unmarked’ use. About the case of reportive speech we will be brief. Here the entailed condition “ $e \subseteq n$ ” is not seen as incoherent, but rather as in agreement with the intuition that it is the utterance time n of the current sentence which locates e . It is arguable whether in such cases the utterance time is to be identified with the duration of e , i.e. whether “ $e \subseteq n$ ” should be strengthened to “ $dur(e) = n$ ”, where $dur(e)$ denotes the duration of e . We leave this for others to decide.

The historical present has certain aspects in common with the reportive present, but there are also important differences. One intuition which has often been expressed about its use is that it is a narrative device to present past events ‘as if they were happening here and now’ – as if the interpreter was in some sense transported to the time when these events did happen. We can capture part of this intuition by assuming that the use of the historical present introduces a fictitious utterance time n' , which is located in the past of the real utterance time n and cotermporal with the described eventuality. In order that we get a coherent interpretation it must be assumed that in those cases where the eventuality is an event e , n' is large enough to temporally include e . For only then can the entailed condition “ $e \subseteq n'$ ” be satisfied. This implies that n' is not only fictitious in that it is situated in the past of the real utterance time n ; it is also very often the case that the time which n' represents must be vastly larger than real utterance times normally are. (53) gives some examples which illustrate this in an increasingly dramatic way.

- (53) a. *Am 19. Mai reist Paulchen von London nach Aberdeen.*
 “On the 19-th of May Paulchen travels from London to Aberdeen.”
- b. *1066 erobert William the Conqueror den Großteil Großbritanniens.*
 “*In 1066 William the Conqueror takes possession of much of Britain.*”
- c. *Die ersten Wirbeltiere entstehen im Ordovizium.*
 “*The first vertebrate species establish themselves during the Or-*

dovician.”

These examples also show another feature of the historical present, viz. that it can combine with locating adverbs which refer to times before the real utterance time n .

An aspect which the historical present shares with its reportive use is that the utterance time typically ‘moves on’ as the discourse proceeds. For the events described in successive sentences of a discourse in the historical present quite often follow each other, rather than being simultaneous. In cases of the historical present this is typically made explicit through the use of adverbs which refer to successive times. For instance, (53.a) could be followed by *Am 21. macht er einen Tagesausflug nach St. Andrews.* (Engl.: *On the 21-th he makes a day trip to St. Andrews.*) The combined effect of successive n 's, with each of them standing for a substantial stretch of time, can produce in the recipient a sense of moving through time, sometimes at vertiginous speed.

Given our assumption that historical uses of the present tense give rise to fictitious utterance times n' , the contribution which the historical present makes to sentence interpretation can be represented as in (54).

$$(54) \text{ Historical Present } \rightsquigarrow \begin{array}{|c|} \hline n' \downarrow t_t \downarrow t_{loc} \\ \hline n' \prec n \\ n' = t_t \subseteq t_{loc} \\ \hline \end{array}$$

Note that this ‘entry’ allows for n' , and with it the described event e , to be included within the time denoted by a temporal adverb when this time lies entirely in the past of the real utterance time n . It should also be clear that the representation of a sequence of successive sentences in the historical present will involve a sequence n'_1, \dots, n'_k of fictitious utterance times, as a rule related to each other as “ $n'_1 \preceq n'_2 \preceq \dots \preceq n'_k$ ”. (In this last respect the historical present resembles the reportive present. There too a sequence of present tense sentential utterances gives rise to a sequence of utterance times “ $n'_1 \prec n'_2 \prec \dots \prec n'_k$ ”; the only differences are that in this case the n'_i usually represent truly successive times (i.e. we have $n'_i \prec n'_{i+1}$ instead of $n'_i \preceq n'_{i+1}$).

The last issue of this section is the distinction between what we call *genuine ambiguity* and *cognitive underspecification*. This distinction is

relevant to the theory of natural language interpretation generally, but the German present tense provides a particularly salient illustration of it. The distinction will play an important part in the proposals we will make in Section 6.

We noted that the simple German tenses allow for progressive as well as non-progressive interpretations. In normal uses of the present tense, we saw, only the progressive interpretation of the present tense is viable. But for many utterances of past and future tense sentences both options are genuinely available, and the same is true for certain ‘marked’ uses of the present tense. An example is (55), occurring in a live broadcast of a football match.

- (55) *Jetzt beschwert er sich beim Schiedsrichter.*
(Now he is complaining to the referee.)

This utterance can either be taken (i) as the statement of a complete event, which is over the moment when (55) is produced, or (ii) as something that is still going on while the utterance is made.

But how realistic is this assessment of the possible interpretations of (55)? Would listeners actually make such a distinction, in that they represent (55) either as (i) or as (ii), or feel they aren’t following what the reporter is saying if they cannot decide which of the two he intended? Probably not. In all likelihood their interpretations would be neutral between (i) and (ii) and the question of how to choose between them simply wouldn’t arise. We dub such interpretations, which retain neutrality with regard to certain interpretational options, *cognitively underspecified* (with respect to those options).

Cognitive underspecification is a common phenomenon. Not only do we find underspecification with regard to the progressive-non-progressive distinction with all simple tenses – the past tense sentence *Er beschwerte sich beim Schiedsrichter* will as a rule give rise to the same kind of underspecification as (55) –, cognitively underspecified interpretations are also a frequent and natural response to utterances involving many other polysemous words and morphemes.

Cases of lexical ambiguity that can (and often do) give rise to cognitively underspecified interpretations must be distinguished from those which do not tolerate such interpretations (i.e. which must always be resolved). An example of this latter kind of ambiguity (according to our

intuitions) the choice between habitual and progressive interpretations. An example is (56).

- (56) *Paulchen gewinnt!*
 ‘Paulchen wins!’

This sentence allows for both a progressive and a habitual interpretation. But this is a case of genuine ambiguity: So long as one hasn’t assigned to an utterance of these words either a episodic-progressive reading or a habitual-generic one, one cannot claim to have understood what the speaker said.²⁴

Exactly when ambiguities may be retained and when they must be resolved is a complicated question, and in many cases there may not be any clear answer. It is a question that we cannot go into here. But it raises some preliminary issues that do fall within the scope of this paper: how is the ambiguity of words and morphemes to be represented in the lexicon, and how are ambiguous lexical specifications integrated into the representations of sentences containing ambiguous lexical items? These issues are directly relevant to the aims of this paper. They will be discussed in the next section.

6 Lexical Ambiguity and Underspecification

In this section we extend our formalism to cover (i) underspecified lexical entries for ambiguous words and morphemes, and (ii) sentence representations that are underspecified with respect to ambiguities of the ambiguous words and morphemes occurring in the represented sentences. As in earlier sections our main concern is to show how underspecifications in initial representations can be resolved, and how resolution is often possible because of the interactions between them. In the present section the

²⁴Think for instance of a use of (56) on an occasion where Paulchen is sitting behind a stack of chips which, like on most other occasions where he takes part in a game, is steadily growing. In this situation both readings are plausible. And yet, one cannot escape the sense that the speaker must have meant either one or the other, and that you cannot claim to have understood what he said so long as you don’t know which one he intended.

emphasis will be on the resolution of lexical ambiguities and on the interaction between lexical underspecification and ups- and downs-unification. The section shares with the last one its forms on the present tense. But the means we develop to deal with different uses and interpretations of the present tense are, we believe, applicable far more widely.

We represent lexical ambiguity with the help of the operator $\overset{\downarrow}{\vee}$. Syntactically $\overset{\downarrow}{\vee}$ functions much like the disjunction operator \vee of DRT – it serves to turn two or more DRSs into a single UDRS-condition. Superficially $\overset{\downarrow}{\vee}$ -conditions just look like disjunctions. But from a semantical point of view this is not what they are, or at any rate not quite. For instance, a condition of the form “ $K_1 \overset{\downarrow}{\vee} K_2$ ”, where K_1 and K_2 are DRSs, should not be confused with the disjunctive DRS condition “ $K_1 \vee K_2$ ” of standard DRT. The latter expresses the familiar truth conditions of (inclusive) disjunction: it is true in all worlds or situations in which either K_1 is true or K_2 is true (or both are). In contrast, “ $K_1 \overset{\downarrow}{\vee} K_2$ ” serves as an indication that each of K_1 and K_2 remains available as an interpretational option.

The difference between “ $K_1 \overset{\downarrow}{\vee} K_2$ ” and “ $K_1 \vee K_2$ ” is particularly clear where the choice between K_1 and K_2 that is expressed by “ $K_1 \overset{\downarrow}{\vee} K_2$ ” is an instance of genuine ambiguity. In this case a representation containing “ $K_1 \overset{\downarrow}{\vee} K_2$ ” is incomplete, and meaningful only as a step towards a complete interpretation, which will be reached only when “ $K_1 \overset{\downarrow}{\vee} K_2$ ”, is resolved, i.e. when it is replaced either by K_1 or by K_2 . This difference is most striking for negative occurrences of \vee - and $\overset{\downarrow}{\vee}$ -disjunctions. For instance, a UDRS of the form (57.a) is logically equivalent to the conjunction (57.b). Such an equivalence does not hold between (57.c) and (57.b). Instead the ‘locally underspecified’ UDRS (57.c) is equivalent to its ‘globally underspecified’ expansion (57.d).

- (57) a. $\neg(K_1 \vee K_2)$
 b. $\neg K_1 \wedge \neg K_2$
 c. $\neg(K_1 \overset{\downarrow}{\vee} K_2)$
 d. $\neg K_1 \overset{\downarrow}{\vee} \neg K_2$
 e. $K_1 \overset{\downarrow}{\vee} K_2$

(57.c) and (57.d) are equivalent in the sense that whatever reasons may eliminate one of the alternates in (57.c) will similarly justify the elimination of the corresponding alternate of (57.d). Suppose for instance that (57.c) is the representation of an utterance made in a context C and that its alternate K_1 is incoherent in C (because it imposes constraints on the context that C cannot meet). Then K_1 can be discarded and what remains of (57.c) is $\neg K_2$. This very same result would have been obtained had (57.d) been chosen as representation of the utterance. The alternate $\neg K_1$ would have been incoherent in C for the same reasons as K_1 and its elimination from (57.d) would have left the other alternate $\neg K_2$.²⁵

We refer to $\overset{!}{\vee}$ and the conditions formed by means of it as *alternations*. The constituents of an alternation are called its *alternates*. (Thus K_1 and K_2 are alternates of the alternation (57.e).)

Adding $\overset{!}{\vee}$ to our UDRT formalism means that representations can now be underspecified in three different ways rather than two: (i) through unresolved ups- or downs-variables, (ii) through indeterminate scope relations, and (iii) through occurrences of $\overset{!}{\vee}$. In general the resolution of such UDRSs will involve simultaneous interactions between underspecifications of all three kinds, but this most general case will not be considered here. In Sections 3 and 4 we looked at examples involving (i) and (ii); in this section we focus on interactions between (i) and (iii).

As we mentioned in Section 5, the simple tenses of German admit of progressive as well as non-progressive interpretations. The first example of this we will look at is the past tense sentence (59).

²⁵For a concrete example: the German verb *lassen* is ambiguous between ‘bring it about that’ and ‘allow it to be the case that’. Thus the sentence (58.a) is ambiguous between (58.b) and (58.c).

- (58) a. *Er lässt den Altbau renovieren.*
 b. *He has the old building renovated.*
 c. *He permits the old building to be renovated.*
 d. *Er lässt den Altbau nicht renovieren.*

Suppose that the (58.b) reading is represented as K_1 and the (58.c) reading as K_2 . Then a representation of (58.a) which is underspecified with regard to the ambiguity of *lassen* takes the form (58.e) and an underspecified representation of (58.d) can be given either in the form (57.c) or in the form (57.d).

- (59) *Paulchen gesundete.*
 “Paulchen recovered.”

One way to capture the progressive-non-progressive ambiguity is to introduce an interpretation rule like that proposed in treatments of the English progressive which transforms given non-progressive interpretations into progressive ones. For English, where the progressive is morphologically expressed, the natural way to deal with its semantics is as follows. We assume that the syntactic structure for a progressive sentence contains an operator *prog* – situated somewhere between the verb and INFL, we ignore the exact details – and that the semantic contribution of *prog* is represented in our formalism by the entry (60).^{26 27}

$$(60) \text{ prog} \rightsquigarrow \boxed{\begin{array}{c} \text{s} \\ \uparrow_t \subseteq \uparrow_{loc} \subseteq \text{s} \\ \downarrow_{t_t^e} \downarrow_{t_{loc}^e} \\ \text{s:PROG } (\lambda e. \boxed{e = \uparrow_e \subseteq t_t^e \subseteq t_{loc}^e}) \end{array}}$$

It might be thought that we can deal with progressive interpretations of German sentences along similar lines, viz. by assuming a tacit operator \emptyset_{prog} at the level of syntactic representation. This operator would have the same semantics as *prog* – that is: \emptyset_{prog} and *prog* have the same lexical entry (60) – and it would be optional in the sense that a sentence like (59) would admit two syntactic structures, one with \emptyset_{prog} and one without it. Specifically, let us assume for *gesundeten* the lexical entry

²⁶According to this entry the semantics of the progressive is located in the event type operator PROG. The actual truth conditions connected with PROG are articulated in the model-theoretic semantics for the representation formalism. See [18].

²⁷One effect of the use of an event discourse referent *e* (instead of an unrestricted eventuality discourse referent *ev*) is that the discourse referent directly bound by the variable $\downarrow_{t_t^e}$ must be an event variable.

By the eventuality variable *directly bound by* a variable \downarrow_{t_t} occurring in a component *l* of a UDRS **K** we understand the unique eventuality variable α such that the UDRS-component of the variable \uparrow_t which is unified with \downarrow_{t_t} contains either the condition ‘ $\alpha \subseteq \uparrow_t \subseteq \uparrow_{loc}$ ’ or the condition ‘ $\uparrow_t \subseteq \uparrow_{loc} \subseteq \alpha$ ’. An eventuality variable α in a UDRS **K** for a given finite sentence *S* is said to be *directly bound by tense* iff it is directly bound by the variable \downarrow_{t_t} introduced into **K** by the tense of *S*.

in (61). Then we would obtain the progressive interpretation for (59) from the syntactic structure which contains \emptyset_{prog} and the non-progressive interpretation from the syntactic structure which doesn't.

$$(61) \text{ } gesunden \rightsquigarrow \boxed{\begin{array}{c} e \\ e:gesunden(\mathbf{x}^{subj}) \\ e \subseteq \uparrow_t \subseteq \uparrow_{loc} \end{array}}$$

What speaks against treating the progressive-non-progressive alternation in this way is that it confers upon the alternation the status of a genuine ambiguity: either the syntactic structure of (59) does contain \emptyset_{prog} and in that case the sentence is assigned its progressive interpretation, or the syntactic structure does not contain \emptyset_{prog} and then the non-progressive interpretation results. What we want is a single representation in which the choice between progressive and non-progressive can be left undecided (though it should also be possible to resolve it if the context permits resolution). One way in which the construction of such a single representation can be secured is as follows: We assume that the syntactic structure of a sentence like (59) contains a covert operator \emptyset_{prog} somewhere along the projection line of the verb. \emptyset_{prog} is underspecified as between (i) making the same contribution as the English operator *prog*, and (ii) not making any semantic contribution at all. Converting a syntactic tree with an occurrence of \emptyset_{prog} will then yield a semantic representation that is underspecified in the relevant manner.²⁸ That is, we adopt as entry for \emptyset_{prog} the one given in (63).

²⁸We leave open exactly where in the syntactic tree \emptyset_{prog} is to be adjoined. A potential problem are those sentences in which the subject of the verb must be construed as semantically within the scope of *prog*, as in the following example (cf. [36], [15]).

- (62) *Seit gestern Abend tropfte Wasser von der Decke.*
'Since last night water was dripping from the ceiling.'

In syntactic theories in which the subject occupies a high position in the tree (e.g. as 'spec of IP', as we have assumed in the syntactic structures we have been assuming in Part I) such sentences will either require \emptyset_{prog} to occur in an even higher position, or else involve some form of reconstruction. We leave this as a problem for further elaboration.

A further question is whether the occurrence of \emptyset_{prog} in sentence trees should be optional. Optionality would mean that besides a representation which is underspecified with regard to the progressive-non-progressive distinction, it is also possible to

$$(63) \quad \emptyset_{prog} \rightsquigarrow \left[\begin{array}{c} s \\ \uparrow_t \subseteq \uparrow_{loc} \subseteq s \\ s:PROG (\lambda e. \left[\begin{array}{c} \downarrow_{t_t^e} \downarrow_{t_{loc}^e} \\ e = \uparrow_e \subseteq t_t^e \subseteq t_{loc}^e \end{array} \right]) \end{array} \right] \downarrow \checkmark \left[\begin{array}{c} e \downarrow_{t_t^e} \downarrow_{t_{loc}^e} \\ e = \uparrow_e \subseteq \uparrow_t \subseteq \uparrow_{loc} \\ \uparrow_t = t_t^e ; \uparrow_{loc} = t_{loc}^e \end{array} \right]$$

The left hand side alternate in (63) is identical with the semantics of prog in (60). The right hand side is designed so that it passes up the UDRS component which unifies with its downs-variables unmodified to the component that unifies with its ups-variables. (In other words, this alternate acts as the identity operator on the inputs that it receives through the unification of its downs-variables. Given the general architecture of our formalism this is guaranteed by the conditions ‘ $\uparrow_t = t_t^e$ ’ and ‘ $\uparrow_{loc} = t_{loc}^e$ ’, which ensure that the ups- and downs-variables of the alternate get the same values.)²⁹

Using (63) and the entry (61) for *gesund* we obtain for (59) the initial UDRS given in (64).

obtain a sentence interpretation which is unambiguously non-progressive. Given the other assumptions we have made in this paper, no verifiable empirical consequences seem to hang on this question.

²⁹Just as in (60), an event variable has been added to each of the alternatives of (63) so as to make sure that (63) only applies to event structures. Sentences with stative verbs are interpreted via syntactic structures without \emptyset_{prog} .

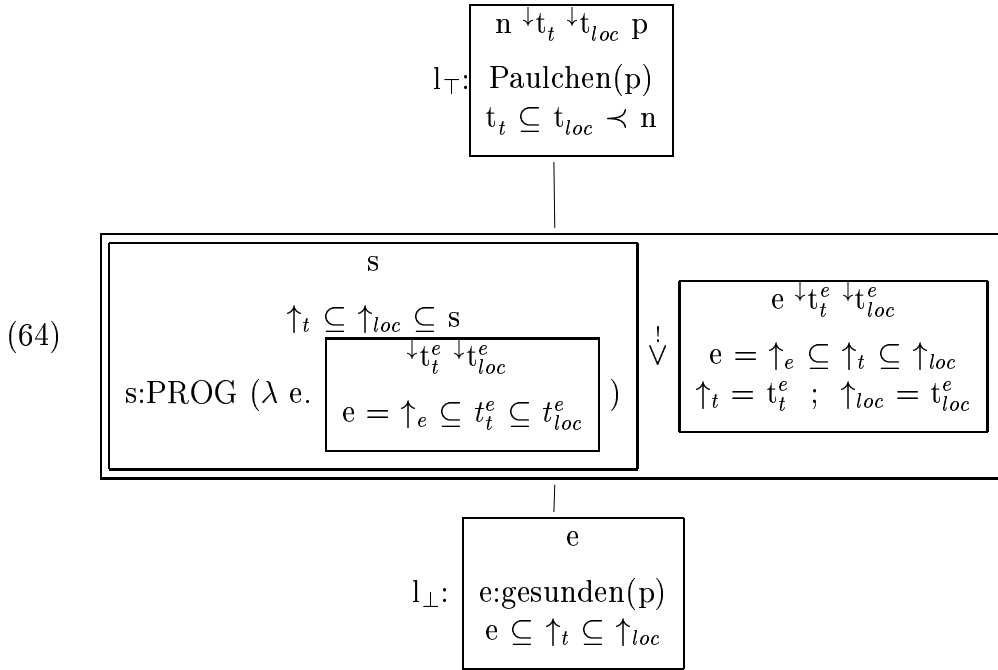

Resolutions of UDRSs like (64), which contain alternations, must treat each alternate of a given alternation as if it were a replacement for the alternation to which it belongs. For the case of (59) this means that the downs-variables of the left hand side alternate of the alternation in the middle must unify with the ups-variables of the bottom component and its ups-variables with the downs-variables from the component at the top; and the same applies to the alternate on the right. When these unifications are carried out, we obtain the representation in (65).

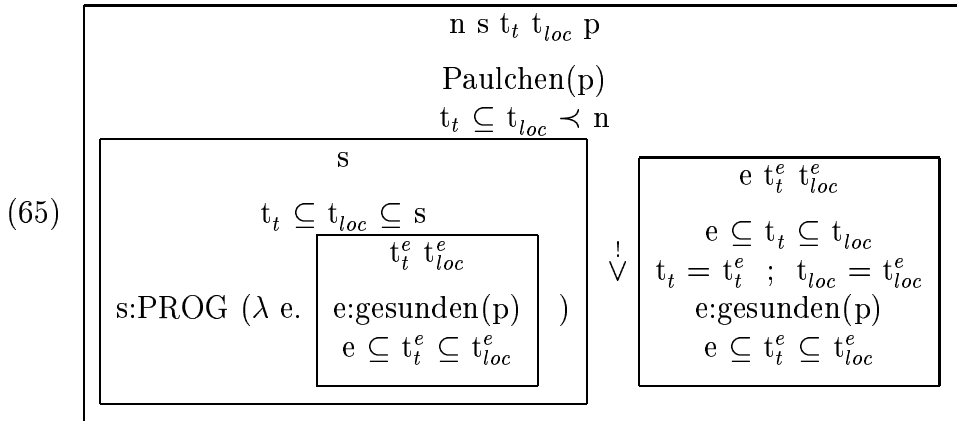

(65) represents the final, cognitively underspecified representation of (59).

(59) differs, we saw, from the present tense sentence (56), which gets an unequivocally progressive interpretation unless its present tense is being used in one of its ‘marked’ ways (reportive present, historical present, etc.). In the light of our discussion of the present tense in Section 5 the most natural account of the elimination of the progressive interpretation of (56) would appear to be one according to which it is the result of applying a filter at a ‘pragmatic’ interpretation stage, which comes after the stages with which we have been dealing in this paper so far. This filter is triggered by the normal use of the present tense and it filters out all those alternatives in the representations of ‘unmarked’ uses of present tense sentences which entail the condition ‘ $ev \subseteq n$ ’, where ev is the eventuality discourse referent directly bound by tense. (See footnote 27.)

The commitments we have so far made in this section in relation to the German present tense are as follows:

- (i) Like other German tenses the German present is underspecified as regards progressive and non-progressive interpretations; however, this underspecification is not to be located in the lexical specification of the present as such, but rather is the contribution made by a semantically underspecified aspect operator.
- (ii) The speech act-related restrictions on the interpretation of present tense sentences, which exclude the non-progressive interpretation, are imposed at a pragmatic level of processing, which comes after the stages described in earlier sections, at which ups-and-downs unification takes place.

As we noted in Section 5 the German present has apart from the progressive and non-progressive interpretations to which these commitments pertain, two further interpretations, the habitual and the prospective one. The first of these is like the choice between progressive and non-progressive interpretation a property the present shares with other tenses. (The fact that present tense sentences tend to allow for habitual readings more easily than past or future tense sentences is presumably connected

with the ‘normal-present-tense-use’ filter sketched above.) Since, as we argued earlier, the distinction between habitual and non-habitual readings is a case of genuine ambiguity, it seems natural to assume that habitual readings are the result of applying a tacit aspect operator \emptyset_{hab} , with a fully specified semantics. In other words, the entry for \emptyset_{hab} should be like (60) for English prog, and not like the underspecified entry (63) we proposed for \emptyset_{prog} .³⁰ The entry is given in (66).

$$(66) \quad \emptyset_{hab} \rightsquigarrow \boxed{\begin{array}{c} s^{hab} \\ \uparrow_t \subseteq \uparrow_{loc} = s^{hab} \\ s^{hab}: \text{HAB } (\lambda \text{ ev. } \boxed{\begin{array}{c} \downarrow_t^{ev} \downarrow_{loc}^{ev} \\ \uparrow_{ev} \subseteq s^{hab} \end{array}}) \end{array}}$$

In order that we can obtain both habitual and non-habitual interpretations for the same sentence, \emptyset_{hab} must be optional: the same sentence must admit both a syntactic analysis with \emptyset_{hab} and one without \emptyset_{hab} . The first of these gives rise to a habitual interpretation, the second to the non-habitual reading.³¹³²

³⁰Note that the semantics of (66) differs from the left hand side of (63) in that its second condition is ‘ $\uparrow_t \subseteq \uparrow_{loc} = s^{hab}$ ’, where (63) has ‘ $\uparrow_t \subseteq \uparrow_{loc} \subseteq s^{prog}$ ’. The reason is the same as in the case of adverbial quantification. The characteristic property of s^{hab} – that events of the kind described occur ‘habitually’ during the period of time it covers – need not be shared either by states that temporally include s^{hab} or by states temporally included within it. Therefore temporal adverbs must be allowed to fix the duration of s^{hab} completely and not just to provide a minimal interval within which the state is included. For the progressive the weaker condition is adequate. For details see Section 3.

³¹ \emptyset_{hab} also gives rise to the same questions about possible attachment sites as \emptyset_{prog} (see footnote 28).

³²The way in which we have captured the distinction between the ‘genuine’ habitual-non-habitual ambiguity on the one hand and the underspecification-like progressive-non-progressive opposition on the other is by treating the first as a case of syntactic ambiguity while capturing the second via an underspecified lexical entry. We do not see this way of dealing with the difference as a definitive solution. For one thing the solution will collapse when underspecification is adopted also at the level of syntax, in coordination with the forms of semantic underspecification we have proposed. More specifically, when syntactic representations can be underspecified with regard to the question whether they contain an occurrence of \emptyset_{hab} and such underspecified syntac-

The prospective interpretation option is specific to the German present tense, and so it should be made a part of its lexical entry. The alternation operator $\overset{!}{\vee}$ might suggest the following modification of the proposal made in Section 3.3:

$$(67) \quad \boxed{\begin{array}{c} \downarrow t_t \downarrow t_{loc} \\ n = t_t \subseteq t_{loc} \end{array}} \overset{!}{\vee} \boxed{\begin{array}{c} \downarrow t_t \downarrow t_{loc} \\ n \prec t_t \subseteq t_{loc} \end{array}}$$

Let us see how this entry enables us to account for the prospective interpretations of the sentences (3.b,e) mentioned in Section 1:

- (3) b. Paulchen kommt.
 e. Paulchen ist morgen krank.

We first consider (3.e). Its initial UDRS is given in (68). Ups-downs unification requires the \uparrow_{loc} of l_{\perp} to unify with both $\downarrow t_{loc}$ from l_{\top} and $\downarrow t_{loc}^m$ from l_m . So we get ' $t_{loc} = t_{loc}^m$ '. In view of this the left alternate of l_{\top} leads to a contradiction between ' $n \subseteq t_{loc}$ ' on the one hand and ' $n \subseteq t' \supseteq t'' = t_{loc}^m = t_{loc}$ ' on the other. So this alternate is eliminated. The other alternate leads to a coherent interpretation: ' $n \subseteq t' \supseteq t'' = t_{loc}^m = t_{loc}$ ' is consistent with ' $n \prec t_t \subseteq t_{loc}$ '. So we arrive at the prospective interpretation of the present tense in (68) as the only possible one.

tic representations yield semantic representations that are underspecified as regards whether they contain an instance of the semantic component of (66), we lose the distinction we are after, unless other provisions are made. Since we consider syntactic underspecification as a desirable development – joint underspecification at both the levels of syntax and semantics is a current trend within computational semantics; see e.g. [46], [53], [5] – we certainly wouldn't want our proposals in this paper to be at odds with such a development. This entails that the difference between genuine ambiguity and underspecification will have to be captured in some other form, e.g. by replacing the single underspecification operator $\overset{!}{\vee}$ by two or more distinct underspecification operators.

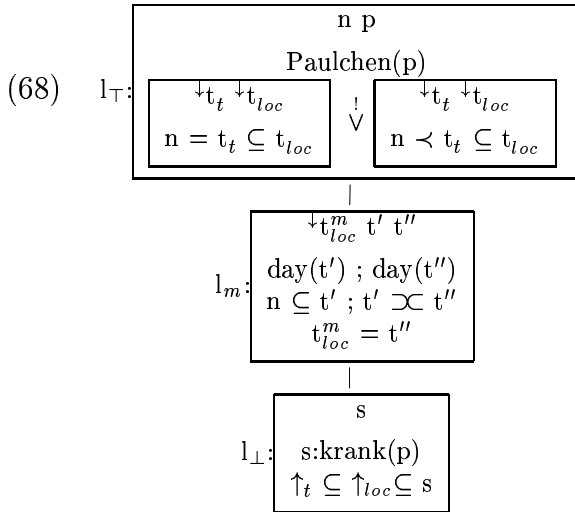

The initial representation of (3.b) (= *Paulchen kommt.*) differs from (68) in that (i) it has only two UDRS-components instead of three and (ii) l_{\perp} now describes an event e rather than a state s , and thus contains the condition ' $e \subseteq \uparrow_t \subseteq \uparrow_{loc}$ ' instead of ' $\uparrow_t \subseteq \uparrow_{loc} \subseteq s$ '. For an unmarked use of (3.b) it is once more impossible to choose the left alternate, but this time the reason is that because the condition ' $e \subseteq n$ ' which would be entailed by this choice is incompatible with such uses of the present tense. So again only the prospective interpretation survives.

If (3.b) is used in one of the marked ways, the prohibition against ' $e \subseteq n$ ' doesn't hold and our treatment predicts that the left alternate is now a viable option.³³

While our treatment accounts for the fact that the present tense of (3.e) (= *Paulchen ist morgen krank.*) and unmarked uses of the present tense of (3.e) only get a prospective interpretation, it cannot explain why (69) only has the non-prospective reading.

³³As a matter of fact it is hard to imagine a reportive use of (3.b) in which it is understood non-prospectively. In this respect the verb *kommen* differs from others which do permit non-prospective interpretations of reportive uses of their present tense forms. For instance a reportive use of *Paulchen kommt herein* (Engl: 'Paulchen enters.') can be understood non-prospectively; in fact for this sentence it is the prospective interpretation which seems hard to get. How the interpretations of reportive and other 'marked' uses depend on the choice of verb is a topic which will need a separate investigation. The use of (3.b) as a historical present raises much the same questions as its reportive use. We forego the details.

(69) *Paulchen ist krank.*

The reason is that (67) fails to impose any kind of ranking on its alternates. This is an aspect of the semantics of the present tense, and of ambiguous lexical items generally, which our operator \checkmark doesn't provide. A more refined way of representing lexical ambiguity is needed here, in which alternates can be weighted, ranked and/or annotated with admissibility constraints.

We conclude this section with a pair of examples which involve not only underspecification of morphemes like tenses or aspect operators, but also an underspecification connected with a word. We saw in Section 3 how correct interpretations for (18) and (23) can be obtained, but not so far for (24), repeated here as (70).

(70) *Heute rief Paulchen oft an.*

The problem presented by (70) is closely related to the issue discussed in 3.3: simple past tense sentences like (70) speak about the past and only about the past. For (70) this means that what it speaks about is confined to that part of today which precedes the speech time. Suppose that the lexical entry for the adverb *heute* is the intuitively obvious analogue of our entry (14) for *gestern*:

$$(71) \textit{ heute} \rightsquigarrow \left\langle \left\{ \begin{array}{c} t' \\ \text{day}(t') \\ n \subseteq t' \end{array} \right\}, \begin{array}{c} \downarrow t_{loc}^h \\ t_{loc}^h = t' \end{array} \right\rangle$$

Then our algorithm won't assign (70) the right semantics. In fact, it doesn't assign (70) a coherent reading at all, since the variable $\downarrow t_{loc}$ contributed by tense must unify with the variable $\downarrow t_{loc}^h$ contributed by the entry for *heute* (since both must unify with the \uparrow_{loc} from the component contributed by the verb), while (71) and our entry for the past tense (see Section 3.3) impose on these variables incompatible constraints ($n \subseteq \downarrow t_{loc}^h$ and $\downarrow t_{loc} \prec n$). The problem is evidently that *heute* – and the same goes for other adverbs whose denotations properly include n – must admit besides its 'primary' denotation, given in (71), also a denotation which is included in the part of today which precedes n (and also one included in that part of it which follows n).

An entry which provides for these additional options is that in (72)

$$(72) \text{ heute} \rightsquigarrow \left\langle \left\{ \begin{array}{c} t' \\ \text{day}(t') \\ n \subseteq t' \end{array} \right\}, \boxed{\begin{array}{c} \downarrow t_{loc}^h \\ \begin{array}{ccc} \begin{array}{c} t_{loc}^h \subseteq t' \\ t_{loc}^h \prec n \end{array} & \downarrow \vee & \begin{array}{c} t_{loc}^h = t' \\ \downarrow \vee \\ \begin{array}{c} t_{loc}^h \subseteq t' \\ n \prec t_{loc}^h \end{array} \end{array} \end{array} \right\rangle$$

It is easily seen that a representation for (70) that is constructed with the help of (72) says what we want: That there is a period of time which precedes n , which is included within the day of n and is characterized by the fact that many wins of Paulchen are included within it. The representation construction now succeeds because the second and third alternate of (72) are both in conflict with the constraint imposed by the past tense, while the first alternate is compatible with that constraint and thus survives.³⁴

Compare this last case with what happens when we apply the construction algorithm to (73), using entry (72) for *heute* and entry (67) for the present tense. Of the two alternates introduced by (67) the first selects the middle alternate of (72) and the second the alternate on the right. So we end up with the underspecified representation given in (74).

(73) *Heute ruft Paulchen oft an.*
(Today Paulchen often calls.)

³⁴Note that if the representation is constructed in accordance with our proposal for dealing with the progressive non-progressive distinction via the semantically underspecified operator \emptyset_{prog} (see (63)), it will be underspecified with respect to this distinction. Thus if we make the further assumption that \emptyset_{prog} is in the scope of *oft* (which is plausible in view of general principles governing the scope relations between aspect operators and temporal adverbs that we cannot go into here), then the eventualities contributed by the verb of (70) will be represented as underspecified as to whether they are completed calls or progressive states to the effect that a call is going on. We have ignored this complication, since it is orthogonal to the point of the present discussion and will do so also in our interpretation of the next example.

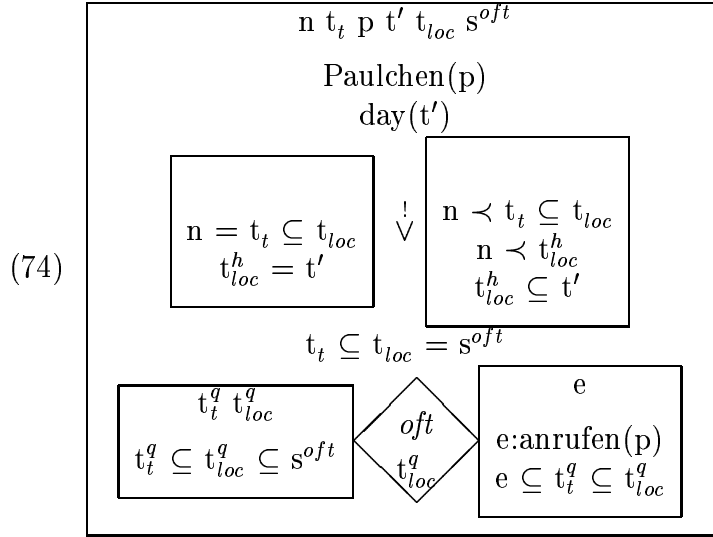

If we abstract from the asymmetry between the two alternate interpretations presented by (74) – again the prospective interpretation seems somewhat harder to get than the speech time oriented one – then (74) gives us just what we want. For the two readings it specifies are just the ones that (70) actually has. Note that this last example differs from the others we have looked at in this section in that it involves two alternations which constrain each other during ups-downs unification.

To summarise this section: we have looked at a few examples of what can happen when lexical ambiguity is added to the sources of underspecification that we investigated in Sections 3 and 4. The alternation operator $\overset{!}{\vee}$ proved to be a helpful device in the representation of lexical ambiguity and underspecification. But $\overset{!}{\vee}$ doesn't deal with the distinction between ambiguity and underspecification nor with preference relations between alternative readings and the 'coercion' mechanisms which suspend or reverse those preferences. On these points our proposal is in need of further elaboration.

7 The Algorithm

In the course of this paper we have presented constructions of a range of semantic representations. With some of our examples, especially the earlier ones, we made an effort to show individual steps of the construction

procedure, and we hope that in this way we have managed to give a fairly good impression of the principles involved. But an explicit definition of the construction algorithm, for a fragment of German which includes all the sample sentences we have considered, is quite another matter.

Such a definition we won't give here. (Just the syntactic and lexical specification of the fragment, which such a definition presupposes, is a non-trivial and lengthy project, most of which would have little direct relevance to this paper's central concerns.) What we will do is state the principles which govern that aspect of the semantic representation constructions exemplified in previous sections that we see as one of the original contributions of this paper and which has been a focus throughout: The unification between ups-variables and downs-variables.

We begin with a brief description of the over-all architecture of representation construction and then state the rules for ups-and-downs unification. The starting point for the construction of semantic representations are syntactic analyses of sentences given in the tree format familiar from generative grammar. In a first pass the syntactic tree of a given sentence *S* is transformed into an "initial" UDRS. This UDRS is processed further, with the goal of obtaining a sentence representation in the form of a "preliminary" DRS. This representation – which will in general be a preliminary DRS in the sense that it contains explicit representations of presuppositions triggered by elements of *S* – is then subjected to a third procedure in which it is connected with the context in which *S* has been used. It has been a default assumption in recent work on DRT ([26], [27], [18]) that it is during this third processing stage that the presuppositions of the preliminary representation are justified (and their representations consequently eliminated from the sentence representation), whereupon the resulting DRS is merged with the discourse context.³⁵

³⁵However, nothing speaks against dealing with certain presuppositions at an earlier stage. In fact, we have been making use of this possibility in all the constructions we have shown, for instance in assuming that the presupposition connected with the proper name *Paulchen* is dealt with even before the second processing phase gets under way. Many deviations from the default order of the different processing operations are possible, in virtue of the high degree of modularity of our approach and the largely declarative formulations which now exist for UDRS- and DRS-construction (including the formulations which will be given below). It is often expedient to exploit this possibility of deviating from the canonical order by first performing those steps which do not involve non-trivial decisions about ambiguity resolution. The results

The third construction stage has played virtually no part in the discussion of earlier sections, and nothing will be said about it in this one. (We refer the reader to [18] for some of the details on the justification of presuppositions.) Of the first construction stage we have given some samples, but an explicit formulation of the procedure will have to wait till some other occasion, since as we said it requires the explicit definition of a sufficiently inclusive fragment of German. In what follows we focus on the second stage, and more particularly on the principles governing the unification of ups-and downs-variables which occurs during this stage.

We begin by considering the formalism as it was developed in sections 3 and 4, which do not include $\dot{\vee}$. The effect of including $\dot{\vee}$ will be discussed at the end of this section. We base our description of these principles on the assumption that UDRSs are structured as described in the UDRS literature (see ([48], [49]); but in any case, the formal definition of the concept of a UDRS will be repeated below.) As regards the principles themselves, they are divided into two kinds:

1. Principles concerning the types of unifiable variables and corresponding uniqueness requirements.
2. Principles which constrain unification in terms of the order relations between the representation components to which the unified variables belong.

The principles of the first kind should be fairly clear from their illustrations in the examples we have discussed, and they can be stated succinctly. Recall that ups- and downs-variables come in two types, indicated by the subscripts ‘t’ and ‘loc’ on ups-arrows and on down-arrowed variables. In this section we will use ‘t’ and ‘loc’ also as names for these types.

The principles of the first kind can be stated as follows:

Principle 1 Unification is type-specific

Unification must always be between variables of the same type:
downs-variables of type t must unify with ups-variables of type t,

of these steps will then be available to support such decisions if and when they arise during the execution of further processing steps. Early justification of presuppositions is just one example of this strategy.

and conversely; and the same holds for ups- and downs-variables of type loc.

Principle 2 Uniqueness and Exhaustivity

Each downs-variable, whether of type t or of type loc, must unify, and it may unify with only one ups-variable.

Similarly, each ups-variable of type t must unify with exactly one ups-variable.

An ups-variable of type loc may unify with more than one downs-variable of its type.

To state the remaining principles is somewhat more involved than it was for the first two, and it requires some preliminary formal definitions. We recall from the UDRT literature that a UDRS can be defined as a structure $\mathbf{K} = \langle \{l:R_l\}_{l \in L}, \langle L, <_{\mathbf{K}} \rangle \rangle$, where the pairs $l:R_l$ are the components of \mathbf{K} , each one consisting of a label l and a representation R_l ; L is the set of all the labels of \mathbf{K} . \mathbf{K} is to be thought of as a directed graph whose nodes are the members of L and whose edges constitute a binary relation $<_{\mathbf{K}}$ on L . $<_{\mathbf{K}}$ is the skeleton of a strict partial order, in the sense that its transitive closure in L is a strict partial order of L . We refer to the transitive closure of $<_{\mathbf{K}}$ as $<_{\mathbf{K}}^*$. It is assumed that for the sentence UDRSs considered in this paper $<_{\mathbf{K}}^*$ is always a lattice, whose top element is labelled l_{\top} and bottom element l_{\perp} . In the following discussion we will switch back and forth between 'strict' (i.e. asymmetric) relations such as $<_{\mathbf{K}}$ and $<_{\mathbf{K}}^*$ and the corresponding 'weak' (i.e. anti-symmetric and reflexive) relations, like $\leq_{\mathbf{K}}$ and $\leq_{\mathbf{K}}^*$. As usual the weak relations are obtained by adding to the strict relations the identity relations on their fields and conversely the strict relations can be obtained from the weak relations by subtracting these identity relations. (Thus $\leq_{\mathbf{K}}^* = <_{\mathbf{K}}^* \cup \text{Id}(\text{Fld}(<_{\mathbf{K}}^*))$ and $<_{\mathbf{K}}^* = \leq_{\mathbf{K}}^* \setminus \text{Id}(\text{Fld}(\leq_{\mathbf{K}}^*))$, where $\text{Id}(\text{Fld}(\mathbf{R})) = \{\langle x, x \rangle \mid \exists y(\langle x, y \rangle \in \mathbf{R} \vee \langle y, x \rangle \in \mathbf{R})\}$). We recall that the operations which turn strict into weak relations, and vice versa, commute with transitive closure, e.g. $(\leq_{\mathbf{K}})^* = (<_{\mathbf{K}}^*) \cup \text{Id}(\text{Fld}(<_{\mathbf{K}}^*))$.

When (in the course of the second processing phase) a UDRS \mathbf{K} is turned into a DRS \mathbf{K}' , the components of \mathbf{K} are "fitted together" according to rules familiar from UDRT. Fitting together two UDRS components $l:R_l$ and $l':R_{l'}$ can take two forms. The first of these is DRS merge of the representations R_l and $R_{l'}$. The second form occurs in cases where one

of the two components has one or more “slots” for DRSs. In such a case the other component may be inserted into this slot, or into one of the slots. “Insertion” takes the form of DRS-merge of the second component with the empty or schematic DRS which constitutes the relevant slot in the first component. UDRS components which have such slots can be thought of as operators. In the UDRS formalism we have used in this paper the slots which such operator-type components make available are of the following sorts: (i) slots of the complex DRS-conditions involving the logical operators \Rightarrow , \vee , $;$ and \neg (the first three are 2-place, i.e. have two slots, while the last one is 1-place, and thus has one slot); (ii) the slots of duplex conditions used to represent quantifiers (2-place); (iii) the argument slots of the aspectual operators PERF, HAB and PROG (1-place).

We assume that when two components are merged, then the set $\{l, l'\}$ consisting of l and l' serves as label for the merge. When components are fitted together successively, then those combined at later stages may themselves already bear set labels. In such cases the result of merging will be labelled by the union of the labels of the merged components. In this way (and identifying single labels with their singleton sets) the resulting DRS and its sub-DRSs will all get labels that are sets of members of L . These set labels are partially ordered by the accessibility relation on the sub-DRSs of K' (familiar from standard DRT; see e.g. [28]). We represent this partial order as $\leq_{K'}$. $\leq_{K'}$ induces a relation $\leq'_{K'}$ between the labels of \mathbf{K} , defined by:

$$(75) \quad l \leq'_{K'} l' \text{ iff } \exists L, L' (l \in L \wedge l' \in L' \wedge L \leq_{K'} L').$$

In general $\leq'_{K'}$ will not be a partial ordering (in that it won't be anti-symmetric); but it will be a *preordering*. Furthermore, if we define the relation $\equiv'_{K'}$ by:

$$(76) \quad l \equiv'_{K'} l' \text{ iff } l \leq'_{K'} l' \wedge l' \leq'_{K'} l,$$

then $\equiv'_{K'}$ is an equivalence relation on the label set of K' and a congruence relation wrt. $\leq'_{K'}$. $\leq_{K'}$ can be recovered from $\leq'_{K'}$ by dividing out by $\equiv'_{K'}$; that is: the set of labels of the sub-DRSs of K' are the equivalence classes under $\equiv'_{K'}$ and

(77) $L \leq_{\mathbf{K}'} L'$ iff $\exists l, l' (l \in L \wedge l' \in L' \wedge l \leq_{\mathbf{K}'} l')$.

To illustrate these observations we have another look at (48) from Section 3, which is repeated here as (78), this time with labels for all the UDRS-components, but otherwise only with the downs-variables and some conditions containing ups-variables.

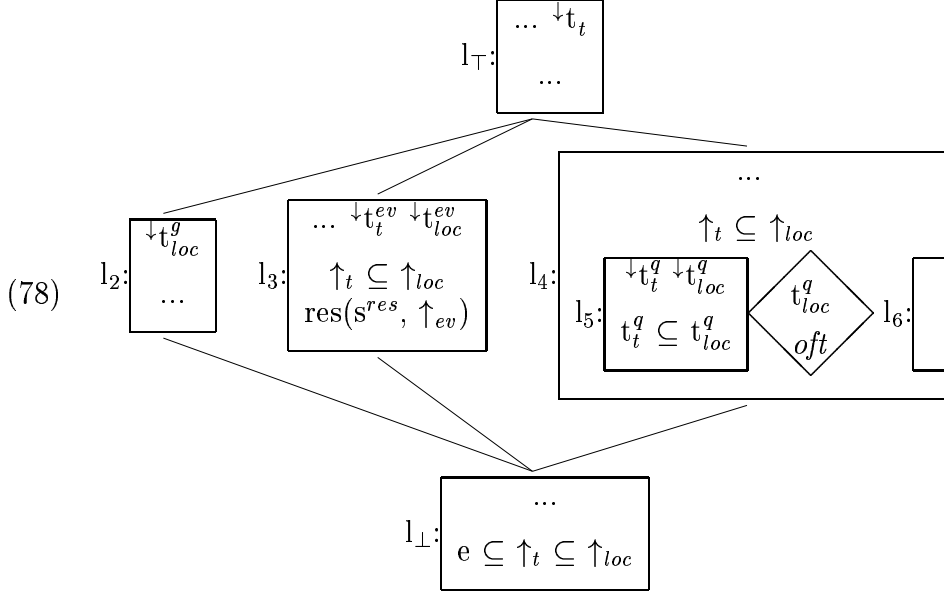

Consider first the DRS (49), which we showed could be obtained from (48). It consists of three sub-DRSs, the main DRS and the restrictor and nuclear scope DRS of the quantificational condition corresponding to *oft*. The labels of the sub-DRSs are $L_M = \{l_\top, l_2, l_3, l_4\}$, $L_R = \{l_5\}$, and $L_S = \{l_6, l_\perp\}$ respectively, which form the accessibility order $L_S <_{(49)} L_R <_{(49)} L_M$. The preorder $\leq'_{(49)}$ induced by $\leq_{(49)}$ can be read off this order directly: $l \leq'_{(49),L} l'$ iff $L \leq_{(49)} L'$, where L and L' are the set labels from the set $\{L_S, L_R, L_M\}$ such that $l \in L$ and $l' \in L'$. Thus we have $l_\perp \equiv'_{(49)} l_6 <_{(49)} l_5 <_{(49)} l_4 \equiv'_{(49)} l_3 \equiv'_{(49)} l_2 \equiv'_{(49)} l_\top$. In the same way we find for the DRS (51) into which (48) can also be resolved: $l_\perp \equiv'_{(51)} l_6 <_{(51)} l_5 <_{(51)} l_4 \equiv'_{(51)} l_\top$.

In the course of resolving the initial UDRS \mathbf{K} into a DRS K' (or to a UDRS \mathbf{K}' which is less underspecified than \mathbf{K}) the original skeleton $<\mathbf{K}$ gets gradually augmented. Ups-downs unifications can contribute

to these augmentations by adding new pairs $\langle l_u, l_d \rangle$, where l_u is the label for the UDRS-component containing the ups-arrow and l_d the label of the component of the downs-variable with which it is unified.

Recall in this connection that for some unifications the corresponding pairs will already be part of the skeleton, but in other cases this will not be so. Only in the latter cases does the unification provide a real augmentation of the skeleton. An obvious constraint on augmentation is that it must be possible for the augmented skeleton to be further extended to produce the partial order of a DRS – more precisely: that there must be a DRS K' to which \mathbf{K} can be resolved such that $\leq'_{K'}$ extends the skeleton augmented by the given unification. This entails that when l_d is *properly below* l_u in the sense that in no resolution K' of \mathbf{K} $l_u \leq'_{K'} l_d$, then the given unification is ruled out (as it would render complete resolution impossible).

We recall in this connection a feature of UDRS resolution that is familiar from the UDRT literature: The labels that occur in the compounds contributed by operators are in general strictly ordered with respect to each other: For instance, the labels l_4 , l_5 and l_6 in the compound contributed by *oft* to (78) stand in the strict ordering relation $l_6 <_{(78)} l_5 <_{(78)} l_4$, and any resolution of the UDRS will have to respect this ordering. One general property of ups- and downs-unification is that they are truly unifications between a 'lower' constituent of the UDRS (the one containing the ups-arrow) and a 'higher' constituent (the one containing the downs-variable).

Summarizing: each time a unification takes place the corresponding pair $\langle l_u, l_d \rangle$ is added to the skeleton $<_{\mathbf{K}}$ if it isn't a member already. And the partial order $\leq_{K'}$ of any DRS K' to which \mathbf{K} can be resolved is an extension of $<_{\mathbf{K}} \cup \{\langle l_u^1, l_d^1 \rangle, \dots, \langle l_u^m, l_d^m \rangle\}$, where the l_u^i, l_d^i are the labels of all the ups-downs unifications that are needed to get from \mathbf{K} to K' .

The principle just described can be seen as a consistency requirement on sets of ups-downs unifications on an initial UDRS \mathbf{K} . Let the pairs $\langle l_u^1, l_d^1 \rangle, \dots, \langle l_u^m, l_d^m \rangle$ be the label pairs which identify the compounds containing the ups- and downs-variables of a set of m potential unifications. Then this set of unifications is said to be *consistent* iff there is a resolution K' of \mathbf{K} such that $<_{\mathbf{K}} \cup \{\langle l_u^1, l_d^1 \rangle, \dots, \langle l_u^m, l_d^m \rangle\} \subseteq \leq'_{K'}$.

We formulate the consistency requirement as one of our constraints on ups- and downs-unification:

Principle 3: Let \mathbf{K} be an initial UDRS and $\{\langle l_u^1, l_d^1 \rangle, \dots, \langle l_u^m, l_d^m \rangle\}$ be the label pairs of m potential ups-downs unifications in \mathbf{K} . Then this set of unifications is admissible only if it is consistent.

We can also state this constraint as applying to stepwise resolution: Suppose that unifications corresponding to the label pairs $\{\langle l_u^1, l_d^1 \rangle, \dots, \langle l_u^m, l_d^m \rangle\}$ have already been carried out and are consistent. Then a further unification is admissible only if the corresponding label pair $\langle l_u^{m+1}, l_d^{m+1} \rangle$ can be added consistently to the given set of pairs, i.e. if $\{\langle l_u^1, l_d^1 \rangle, \dots, \langle l_u^{m+1}, l_d^{m+1} \rangle\}$ is consistent.

There is one further constraint on unification which is not captured by the consistency requirement and needs to be stated separately. This is the principle that when a component of the initial UDRS contains both ups- and downs-variables these may not be unified with each other.

Principle 4: No unification is permitted between ups- and downs-variables that belong to the same component of the initial UDRS.

For the sentence types considered in this paper these principles cover, as far as we can see, all the constraints to which ups-downs unification is subject. Note in particular in this connection that they entail the intuitively desirable prohibition against 'crossing' unifications. What we mean by this is the following: Suppose that the transformation of \mathbf{K} into a DRS \mathbf{K}' involves a unification of a downs-variable belonging to a component of \mathbf{K} whose label is l_d with the ups-arrow of a \mathbf{K} -component with label l_u , and similarly a unification involving the labels l'_d and l'_u . Then these labels may not cross in the sense of the relation $\leq'_{\mathbf{K}'}$. That is, the following is not allowed: $l_u <'_{\mathbf{K}'} l'_u <'_{\mathbf{K}'} l_d$. That such unification combinations are indeed ruled out, at least for the sentence types considered in this paper, follows from (i) the fact that for sentences of any of these types all components of the initial UDRS except those labelled l_{\top} and l_{\perp} have both ups- and downs-variables, whereas the l_{\perp} -component has only ups-variables and the l_{\top} -component only downs-variables, (ii) the 1-1 character of t-type unification (cf. Principle 2) and (iii) the fact that the label of the downs-variable of a unification cannot be properly below the label of the component containing its ups-variable.

Again we can use (78) to illustrate the point. In (78) all unification combinations that are permitted by our principles verify the anti-

crossing constraint. For instance, we cannot simultaneously unify the ups-variables of l_{\perp} with the downs-variables of l_{\top} and the ups-variables of l_3 with the downs-variables of l_5 , leading to $l_u <'_K l'_u$, $l'_u <'_K l'_d$ (for any resolving UDRS K' which involves these unifications), where $l_u = l_{\perp}$, $l'_u = l_3$ and $l'_d = l_{\top}$. The reason is that once the ups-variables of l_{\perp} are unified with the downs-variables of l_{\top} , the only options left for the remaining ups- and downs-variables are that the ups-variables of l_3 unify with the downs-variables of l_5 , adding the ordering constraint $\langle l_3, l_5 \rangle$, and the ups-variables of l_4 with the downs-variables of l_3 , adding the constraint $\langle l_4, l_3 \rangle$. No resolving DRS K' could ever accommodate both these ordering constraints, since necessarily $l_5 <'_K l_4$. Other possibilities of crossing unifications are similarly ruled out.³⁶

So far the considerations of this section have ignored the ambiguity operator $\dot{\vee}$. As we saw in Section 6, ups- and downs-unification treats the alternates of alternations as if they had been substituted for the alternations of which they are part. A UDRS \mathbf{K} with n alternations $\alpha_1^1 \dot{\vee} \dots \dot{\vee} \alpha_{k_1}^1, \dots, \alpha_1^n \dot{\vee} \dots \dot{\vee} \alpha_{k_n}^n$ can be seen as a compressed notation for the set of $\prod_{i=1}^n k_i$ alternate UDRSs which we get by arbitrarily selecting one alternate from each alternation and then replacing each alternation by the selected alternate. Unification then has to be performed on each of these UDRSs.³⁷

³⁶These considerations would not apply to UDRSs with two adverbial components like the one labelled by l_3 in (78). For then the ups- and downs-variables of the two components could in principle be unified crosswise and the two components unified into a single one. First, there is a strong tendency for the operators in question to have their scope relations determined by syntax (e.g., *Paulchen gewann oft zweimal.* vs. *Paulchen gewann zweimal oft.*). In fact we are not aware of any convincing cases of scope ambiguities that are resolved by syntactic form. Should we be mistaken in this, then it would be necessary to add further constraints on unifications. But that is something we will only do when we find we have to.

³⁷In general this procedure may be quite cumbersome and it goes against one of the central motivations of UDRT, viz. to make processing more efficient than it would be if UDRSs are unfolded from the start into explicit disjunctions of all the fully specified structures into which they can be expanded. As suggested by some of the examples discussed in Section 6, unifications of UDRSs with alternations is often possible in a more economical way. General heuristic rules for when and in what form shortcuts are possible are not known to us at present.

8 Conclusions and Comparisons

The central concern of this paper has been to introduce a hitherto unexplored mechanism for the binding of temporal variables, based on the unification of “ups-arrows” and “downs-arrows”. We explored the viability of this mechanism by looking at a variety of different sentence types, each one of them presenting a new twist to the phenomenon of interacting sentence elements that contribute to temporal reference and/or aspect. Section 7 offered a formal description of the unification mechanism that was used in the preceding sections.

Since ups-and-downs unification is pivotal to the account of temporal reference we have presented, we end the paper with a few words on where we see the differences between it and the variable binding mechanisms that are found in other approaches to natural language semantics. (We will be very brief; a proper comparison would require a separate paper.)

One respect in which formal frameworks for natural language semantics differ from each other are the binding regimes they make use of. In the present context two distinctions are important. First there is the distinction between (1) binding systems which in essence follow the principles of predicate logic and (2) those of DRT (and other versions of Dynamic Semantics). The former are based on the binary opposition between (a) variables, subject to binding by quantifiers and other variable binding operators, and (b) constants, which refer to particular entities. Binding in DRT differs from this in two ways: (i) there is no syntactic distinction between variables and constants, quantificational binding and reference are treated as variants of the same general mechanism; (ii) the theory assumes a three-way and not a two-way opposition – between (a) quantificational, (b) indefinite and (c) presuppositional binding; presuppositional binding plays the part of reference in standard logic – all definites are assumed to give rise to a presupposition that they have a uniquely identifiable referent – while indefinite binding is a form of binding specific to Dynamic Semantics (common in natural languages, though not previously recognised in linguistic theory).

Ups-downs unification is an instance of the second, three-way view of binding. But this is only one of its distinctive properties. Its novelty – and here we come to the second distinction – resides in its use of two types of ‘variables’: ‘ups-variables’, which can be seen as identifiers of

argument slots in predicates, and downs-variables, which act like real variables (or, equivalently, discourse referents). Binding in the sense of the last paragraph now involves two separate processes: (a) binding (in the same sense as above) of downs-variables and (b) unification of downs-with ups-variables. (The use of ups- and downs-arrows, implying that the downs-arrow comes from above and the ups-variable from below, is just a graphic reminder of the self-evident well-formedness condition that every occurrence of a bound variable must be in the scope of its binder.)

In the theory we have presented this feature of the ups-and-downs regime serves two related purposes: (i) to allow for computational delay of binding, and (ii) to allow for non-deterministic relations between binders and argument slots. (i) is a concern that the present theory shares with a number of other systems which use only one type of variable - examples are versions of Montague Grammar which employ variable stores (e.g. [8], [3]), UDRT in its original form ([48], [49]), as well as certain more recent versions of DRT ([26]). We do not know of any other approach to temporal reference, however, which allows for non-determinism in the relation between argument slots and the binders of their fillers.

The phenomena that led us to adopt this last feature were discussed at length: In many sentences the scope relations between aspect operators and adverbial quantifiers are underspecified by syntactic form, and different resolutions of the indeterminacies involve different resolutions of the argument slot-binder relations. We have spoken of these phenomena as if they were specific to temporal reference, but as a matter of fact we are not sure that they are confined to the temporal domain. (Nothing we have said in the paper commits us to a stand on this matter.)

The ups-and-downs mechanism doesn't cover all cases of variable binding in our formalism. The formalism also has λ -binding, which is needed to form terms standing for eventuality types which can serve as arguments for aspect operators like PERF and PROG. We believe that neither of ups-and-downs-based binding nor λ -binding can be reduced to the other. (Though as things stand we have no formal proof of this.) It would, however, be possible in principle to redesign the formalism in the spirit of λ -DRT and replace the treatment of quantification via complex conditions by one in which λ -abstraction is combined with general quantifiers as higher order operators. In this modified formalism all forms and aspects of binding discussed in this paper are accomplished by

the following four devices: (i) λ -binding; (ii) higher order predicates like PERF, PROG and generalised quantifiers; (iii) presupposition justification ('presuppositional binding') and (iv) ups-and-downs unification.

An additional feature of the mode of ups-and-downs unification proposed in this paper is the distinction between variables of type 't' and variables of type 'loc'. The motivation for this complication, explained in Section 3, had to do with some fairly subtle properties of the system of temporal reference in German or English. We see no reason why it should extend beyond the temporal system.

8.1 Comparison with other Theories of Tense and Aspect

Because of its emphasis on ambiguity, disambiguation and underspecification, the present paper is quite different from all other treatments of aspect and temporal reference that we are aware of. So comparisons with other approaches are not easy. Nevertheless it may be useful to try to say something about how we see the relations between the proposals of this paper and work that addresses some of the same empirical phenomena.

There is far less we can say here than would do justice to the variety and depth of the tense and aspect literature as it currently exists. The little we will say is organised along two orthogonal dimensions, that of general methodological assumptions and that of covering and explaining empirical facts.

First methodology. The nearest in spirit to the present proposal is the quite extensive work on tense and aspect within DRT. (We remind the reader that concerns about tense and temporal reference were the original impetus towards DRT.) Salient among the DRT-based studies on tense and aspect are [4], [12], [9], [13], [39], [15], and [16]. ([16], which uses UDRT rather than DRT, contains some proposals dealing with the temporal aspects of interpretation, although temporal reference is not a central concern of the paper.) An interesting use of DRT is made in [54], where DRSs are taken as designating mental representations that result from sentence interpretation by human speakers. Not all information specified in such DRSs is relevant to their truth conditions. The additional information they contain may pertain in particular to so-called *viewpoint-aspect*, encoding the perspective from which the content of the

represented sentence is seen. In what we have presented here viewpoint aspect plays no part. But in a more comprehensive theory there should be room for it, so the semantic representations used in such a theory should also be allowed to include information which has no truthconditional impact. Incorporating this conception of semantic representation into a UDRT-based framework (as opposed to a theory which makes use of DRSs but no UDRSs) may not be completely straightforward, but we do not see any serious obstacles.

The bulk of current work on tense and aspect makes use of what has served as the standard formalism of formal semantics since [40]. (In essence this is Higher Order Intensional Logic (HOIL), sometimes its extensional fragment, and often enriched with additional types for time-related entities like instants, temporal intervals, events and/or states.) So long as only the semantics of single sentences is concerned, there isn't all that much to choose between using some suitable variant of HOIL or DRT as semantic representation language. But recasting the proposals of this paper within a HOIL framework would require redeveloping UDRT within that framework; and it would also be necessary to provide a mechanism for indefinite binding along the lines of Dynamic Semantics. Once this would have been done it would be easier to compare our analysis of particular temporal or aspectual phenomena more directly with existing HOIL-based proposals. But the recasting would be a lot of additional work, and it hasn't yet been done.

A further feature that much recent and current work on tense and aspect shares with Montague's own contributions to natural language semantics is the assumption that all ambiguity is either lexical or syntactic: unless an ambiguity in a sentence can be traced to the ambiguity of one or more of its lexical items, the sentence must have several syntactic analyses, each one corresponding to one of the possible interpretations in question.³⁸ We do not think that this assumption can be taken for granted. In fact, it has been one of the basic working hypotheses of UDRT that the assumption isn't generally true: Some syntactic struc-

³⁸This assumption is particularly clear in the work of Von Stechow ([55],[56],[59]) that is carried out within the framework of his 'Transparent Logical Form'. We mention Stechow's work also because we see it as the most comprehensive single effort to deal with problems of tense and aspect within the general framework of Montague Grammar since [14].

tures support more than one interpretation, and often when this is so, it is feasible, and also useful to capture the different interpretations compatible with such an 'ambiguous' syntactic analysis in the form of a single underspecified representation. Exactly which non-lexical ambiguities should be treated as syntactic ambiguities is not easy to decide. Ideally, one wouldn't want to postulate a syntactic ambiguity unless syntactic arguments can be found to support this. But it can be very convenient to treat certain ambiguities as cases of covert syntactic ambiguity, even if independent syntactic support is missing. We ourselves have been 'guilty' of this *modus operandi* when in Section 6 we proposed the syntactically optional operator \emptyset_{hab} .

One question, we just noted, that such assumptions about the syntactic basis of certain ambiguities raise is their syntactic legitimacy. But the matter also has another, computational dimension. From the beginning a central motive behind UDRT has been to render deduction from ambiguous premises computationally efficient: One can deduce a conclusion B from an ambiguous expression A without disambiguating A (i.e. without determining a unique reading for it) by deducing B separately from each of A's possible interpretations. But when the number of interpretations between which A is ambiguous is large – and this is not just a theoretical possibility, but one of the ubiquitous realities of computational applications – this procedure can be computationally costly; in such cases a single deduction of B from a single underspecified representation **K** of A (using the special deduction rules which UDRT makes available for this purpose) can amount to very substantial savings. It is a reasonable assumption (although one for which we haven't provided evidence in this paper) that such efficiency considerations apply also to those deductions that are needed for the disambiguation of A itself – i.e. that it will often be more efficient to disambiguate A by constructing an underspecified representation **K** for it and to carry out the deductions necessary for elimination or reduction of the ambiguities represented by **K** directly on **K** itself than to construct separate representations for each of A's possible readings and then deductively manipulate those.

Locating ambiguities in the syntax may interfere with the method of disambiguating via underspecification. For instance, if an ambiguity is treated by assuming an optional covert operator with a non-ambiguous lexical entry, like the operator \emptyset_{hab} of Section 6, then the possibility of

representing the ambiguity as a case of underspecification will be lost unless we admit underspecification also at the level of syntax. In Section 6 we already stated our conviction that extending underspecification to the level of syntax is desirable in any case. We shrunk from doing this in the present paper. But there is nothing in our set-up which militates against such an extension.

We can see no reason either why the various theory components that are needed in a theory that is capable of representing ambiguity as underspecification – underspecified lexical entries, underspecified syntactic representations and underspecified semantic representations of sentences and discourse which incorporate either or both of these – could not be added on to a theory *T* formulated within a version of Montague Grammar such as, e.g., TLF. *T* could then still be seen as the ‘classical, declarative part’ of the extended theory *T'* to which these additions would lead. In other words, *T* would identify that part of *T'* which states – at a certain level of abstraction, which has proved its immense usefulness in theoretical linguistics – how *T'* explains the phenomena within its scope. To put in another way: we do not see the approach we have advocated in this paper as incompatible with what seems to us to constitute the bulk of current formal work on the problems of tense and aspect (and on problems in natural language semantics generally) and of which TLF is a prominent example. Once more, our aim has been to focus on those aspects of the process of language interpretation which these other approaches – be it out of principle or for some other reason – choose to set aside.

8.1.1 Data-oriented Comparisons

Empirical coverage has not been one of our aims. The range of sentences we have looked at has been quite small, and their choice has been guided by their usefulness as illustrations for our central concerns – ups-downs unification and lexical underspecification and their interactions. There are two areas, however, where our proposals have been fairly detailed and where they differ in certain ways from proposals in the literature which deal with the same phenomena, (i) the perfect and (ii) temporal adverbs. Here a detailed discussion of alternative proposals, and of why we have nevertheless seen fit to present our own analyses, would certainly have been appropriate. But it would have required a considerable amount of

extra space, and we are afraid that it might have detracted from what we see as the paper's central points.

As we implied in Section 4, our treatment of the perfect is one of the proposals of this paper of which we suspect that it may prove to be in need of adjustment when more data are taken into account than we have considered. A good many current theories of the perfect differ from our proposal in that they assume that perfects must always be evaluated with respect to a certain extended temporal interval, currently often referred to as 'Perfective Time Span' (or 'PTS', see [56], and also other contributions to the collection [24] to which this paper belongs). Perhaps the most convincing case that can be made for the need of PTS in the analysis of perfect tenses is [52], which explains the differences between perfect tense forms in English, German and Swedish largely in terms of the properties each of these languages assign to PTS. This cross-linguistic dimension of the problem is one our proposal neither aims nor is able to account for. We do not see any fundamental difficulty in incorporating a PTS-based account of the German perfect into our proposal. But the task is non-trivial and it is still to be done.

As regards adverbial quantification, we already mentioned [10]. Another important publication by De Swart is [11]. Further DRT-based treatments of adverbial quantification can be found in [47], [59] and [43]. There is one aspect of our treatment of adverbial temporal quantification that we believe to be new. This is the analysis of the implicit, context-resolvable restriction on temporal quantification domains as involving (i) a 'frame interval' within which all values of the quantified variable are included and (ii) a 'granularity partition' of that interval which fixes the size of these values. (Apart from this the features which distinguish our treatment of quantification from other treatments have to do with the general architecture of our framework, which requires that the semantic contributions of adverbial quantifiers must on the one hand unify with representation components that fill their nuclear scope or restrictor and on the other hand with a component which anchors their implicit frame interval.)

References

- [1] M. Rathert A. Alexiadou and A. von Stechow. *Perfect Explorations*. Mouton de Gruyter, 2003.
- [2] David Beaver and B. Clark. Always and only. why not all focus sensitive operators are alike. *Natural Language Semantics*, 14:323–362, 2003.
- [3] Maria Bittner. *Case, Scope and Binding*. Kluwer, Dordrecht, 1994.
- [4] A. Borillo, M. Bras, A. Le Draoulec, H. De Swart, H. Verkuyl, C. Vet, and L. Vie. Tense and aspect. In *Handbook of French Semantics*. CSLI-LN, University of Chicago Press, 2004.
- [5] Philipp Cimiano and Uwe Reyle. Talking about trees, scope and concepts. In *Proceedings of the Sixth International Workshop on Computational Semantics IWCS-6*. Tilburg, 2005.
- [6] Bernhard Comrie. *Aspect*. Cambridge University Press, 1976.
- [7] Bernhard Comrie. *Tense*. Cambridge University Press, 1985.
- [8] Robin Cooper. *Quantification and Syntactic Theory*. Reidel, Dordrecht, 1983.
- [9] Henriette de Swart. Aspect shift and coercion. *Natural Language and Linguistic Theory*, 16:347–385, 1988.
- [10] Henriette de Swart. *Adverbs of quantification: a generalized quantifier approach*. PhD thesis, Groningen, 1993.
- [11] Henriette de Swart. Position and meaning: time adverbials in context. In P. Bosch and R. van der Sandt, editors, *Focus: linguistic, cognitive and computational perspectives*, pages 336–361. Cambridge University Press, 1999.
- [12] Henriette de Swart and Arie Molendijk. Negation and the temporal structure of narrative discourse. *Journal of Semantics*, 16(1), 1999.
- [13] Henriette de Swart and Henk Verkuyl. *Tense and Aspect in Sentence and Discourse*. ESSLI Lecture Notes, 1999.

- [14] David R. Dowty. *Word Meaning and Montague Grammar*. Kluwer Academic Publishers, 1979.
- [15] Kurt Eberle. *Ereignisse. Ihre Logik und Ontologie aus textsemantischer Sicht*. PhD thesis, Universität Stuttgart, 1992.
- [16] Kurt Eberle. *Flat underspecified representation and its meaning for a fragment of German*. PhD thesis, Universität Stuttgart, 2004.
- [17] Veronika Ehrich. *Hier und Jetzt. Studien zur lokalen und temporalen Deixis im Deutschen*. Niemeyer, Tübingen, 1992.
- [18] Josef van Genabith, Hans Kamp, and Uwe Reyle. Discourse representation theory. an updated survey. In Dov Gabbay, editor, *Handbook of Philosophical Logic*. Kluwer Academic Press, 2004.
- [19] Bart Geurts and Rob van der Sandt. Presuppositions and backgrounds. In *Proceedings of the 11th Amsterdam Colloquium*. University of Amsterdam, 1999.
- [20] Käte Hamburger. *Die Logik der Dichtung*. Stuttgart, Klett, 1968.
- [21] Irene Heim. *The Semantics of Definite and Indefinite Noun Phrases*. PhD thesis, University of Massachusetts, Amherst, 1982.
- [22] Irene Heim. On the projection problem for presuppositions. In Michael Barlow, Daniel P. Flickinger, and Michael T. Wescoat, editors, *Proceedings of WCCFL 2*, pages 114–125, Stanford, 1983. Stanford Linguistics Association.
- [23] Irene Heim. Artikel und Definitheit. In *Handbuch der Semantik*. Berlin: de Gruyter, 1991.
- [24] Sabine Iatridou, Elena Anagnostopoulou, and Roumyana Izvorsky. Some observations about the form and meaning of the perfect. In M. Rathert A. Alexiadou and A. von Stechow, editors, *Perfect Explorations*. Mouton de Gruyter, 2003.
- [25] Hans Kamp. Disambiguation in discourse. In Michel Aurnague, Andree Borillo, and Myriam Bras, editors, *Semantics of Time, Space and Movement*, 1993.

- [26] Hans Kamp. The importance of presupposition. In Christian Rohrer, Antje Roßdeutscher, and Hans Kamp, editors, *Linguistic Form and its Computation*. CSLI-Publications, Standord, 2001.
- [27] Hans Kamp. Presupposition computation and presupposition justification. In Myriam Bras and Laure Vieu, editors, *Pragmatic and Semantic Issues in Discourse and Dialogue*. Elsevier, 2001.
- [28] Hans Kamp and Uwe Reyle. *From Discourse to Logic*. Kluwer Academic Publishers, 1993.
- [29] Hans Kamp, Uwe Reyle, and Antje Roßdeutscher. Diskursrepräsentation, lexikonbasiert, unterspezifiziert. In James Kilbury and Richard Wiese, editors, *Integrative Ansätze in der Computerlinguistik*, 1995.
- [30] Hans Kamp, Uwe Reyle, and Antje Roßdeutscher. Ups and downs in the theory of information structure. IMS, University of Stuttgart, 2004.
- [31] Hans Kamp and Christian Rohrer. Temporal Reference in French. To appear at CSLI.
- [32] Hans Kamp and Antje Roßdeutscher. Remarks on lexical structure and DRS construction. *Theoretical Linguistics*, 20:97–164, 1994.
- [33] Wolfgang Klein. *Time in Language*. London, New York: Routledge, 1994.
- [34] Wolfgang Klein. An analysis of the German Perfekt. *Language*, 74(2):358–382, 2000.
- [35] Angelika Kratzer. Building statives. In *Proceedings of the Berkley Linguistic Society 26, February 2000*, 2000.
- [36] Manfred Krifka. *Nominalreferenz und Zeitkonstitution*. München:Fink, 1998.
- [37] James D. McCawley. Tense and time reference in English. In Charles Fillmore and D.T. Langendoen, editors, *Studies in Linguistic Semantics*. Holt, Rinehart & Winston, New York, 1971.

- [38] Robert McCord. *The English Perfect: Tense-Choice and Pragmatic Inferences*. North-Holland, Amsterdam, 1978.
- [39] Telmo Mória. *Identifying and computing temporal locating adverbials*. PhD thesis, Universidade de Lisboa, 1999.
- [40] Richard Montague. *Formal Philosophy. Selected Papers of Richard Montague*. Yale University Press, 1974.
- [41] Renate Musan. *The German Perfect. Its Semantic Composition and its Interaction with Temporal Adverbial*. Kluwer Academic Press, 2002.
- [42] Toshiyuki Ogihara. Double-access sentences and reference to states. *Natural Language Semantics*, 3:177–210, 1995.
- [43] Toshiyuki Ogihara. Adverbial quantifiers, maximal situations, and weak e-type pronouns. In *Proceedings of the Western Conference on Linguistics, (WECOL 96)*, volume 9, pages 200–213, Department of Linguistics, California State University, Fresno, 1998.
- [44] Terence Parsons. *Events in the semantics of English*. MIT Press, 1990.
- [45] Barbara Partee. ‘Many’ Quantifiers. In *Proceedings of ESCOL*, 1988.
- [46] M. Pinkal. Radical underspecification. In P. Dekker and M. Stokhof, editors, *Proceedings of the Tenth Amsterdam Colloquium*. ILLC, University of Amsterdam, 1996.
- [47] Ian Pratt and Nissim Francez. Temporal generalized quantifiers. *Linguistics and Philosophy*, 2001.
- [48] Uwe Reyle. Dealing with ambiguities by underspecification: Construction, representation and deduction. *Journal of Semantics*, pages 123–179, 1993.
- [49] Uwe Reyle. Co-indexing labelled DRSs to represent and reason with ambiguities. In Kees van Deemter Stanley Peters, editor, *Semantic Ambiguity and Underspecification*. CSLI Publications, Stanford, 1996.

- [50] Mats Rooth. *Association with Focus*. University of Massachusetts, 1985.
- [51] Mats Rooth. A theory of focus interpretation. *Natural Language Semantics*, 1(1):75–11, 1992.
- [52] Björn Rothstein. *The preterit and the perfect in German and Swedish*. PhD thesis, Institute of Linguistics, University of Stuttgart, 2006.
- [53] Schiehlen. *Semantikkonstruktion*. Doctoral thesis, IMS, University of Stuttgart, AIMS, Vol. 5, No. 3, 1999.
- [54] Carlota Smith. *The Parameter of Aspect*. Kluwer Academic Publishers, 1991.
- [55] Arnim von Stechow. Intensionale Semantik – eingeführt anhand der Temporalität. Fachgruppe Sprachwissenschaft, Universität Konstanz, 1991.
- [56] Arnim von Stechow. Eine erweiterte Extended Now-Theorie für Perfekt und Futur. *Literaturwissenschaft und Linguistik*, 29(113):86–118, 1999.
- [57] Mark Steedman. Temporality. In J. van Benthem and A. ter Meulen, editors, *Handbook of Logic and Language*, pages 895–935. Elsevier North Holland, 1997.
- [58] Kees van Deemter. *On the Composition of Meaning*. PhD thesis, University of Amsterdam, 1991.
- [59] Arnim von Stechow. Temporal prepositional phrases with quantifiers: some additions to Pratt and Francez. *Linguistics and Philosophy*, 25(5–6):755–800, Dezember 2002.